

Service
Service
Service

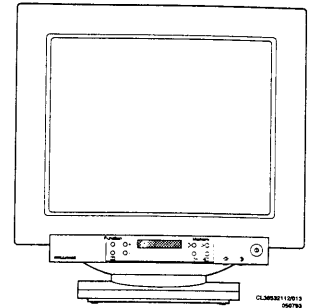

Service Manual

Horizontal frequencies
30 to 82 kHz

Contents

Page

1. Technical data	1
2. Connection facilities	3
3. Warnings and Notes	4
4. Mechanical instructions	4
Abbreviations	4
5. Wiring diagram	5
6. Functional block diagram A	6
Functional block diagram B	7
Functional block diagram C	8
7. Electrical adjustments	9
8. Repair tips	9
9. Directions for use	9
10. Exploded view	13
Spare parts lists	14

1. Technical data

**C2082DAS/II
2020DC****General**

- Mains voltage : 90 - 132V or
180 - 264V
- Mains frequency : 47 - 63Hz
- Power consumption : 180 W
- Operating temperature : 5°C to 40°C
- Weight : 37 kg
- Dimensions (H, W, D) : 485, 498, 538 mm
- Video signal : 0.714 Vp-p
75 Ω / high
impedance
(selectable)

Sync. signal

- Separate sync. : TTL-level
- Composite sync. : TTL-level
- Composite sync. : on Green

Picture tube

- Size : 20 inch (trinitron)
- Light transmission : 39 %
- EHT voltage : 27,5 kVolt
- Pitch : 0.30 mm aperture
grille pitch

Video

- Dot rate : 150 MHz
- Image area:
 - * horizontal : 387,2 mm
 - * vertical : 291,6 mm
- Vertical frequency : 50 - 160 Hz
- Vert. Sync. polarity : positive or negative
- Horizontal frequency : 30 to 82 kHz
- Hor. Sync. polarity : positive or negative
- Resolution : up to 1280x1024 at
76 Hz refresh rate
- Misconvergence : 0.3 mm in the center
0.4 mm in the corners

Preset modes

- Number of preset modes : 22 (14 factory
presets)

* Technical data are subject to change without notice

C2182DAS/II**General**

- Mains voltage : 90 - 132V or
180 - 264V
- Mains frequency : 47 - 63Hz
- Power consumption : 180 W
- Operating temperature : 5°C to 40°C
- Weight : 37 kg
- Dimensions (H, W, D) : 485, 498, 538 mm
- Video signal : 0.714 Vp-p
75 Ω / high
impedance
(selectable)

Sync. signal

- Separate sync. : TTL-level
- Composite sync. : TTL-level
- Composite sync. : on Green

Picture tube

- Size : 21 inch (flat)
- Light transmission : 52 %
- EHT voltage : 27,5 kVolt
- Pitch : 0.28 mm

Video

- Dot rate : 150 MHz
- Image area:
 - * horizontal : 406,4 mm
 - * vertical : 304,8 mm
- Vertical frequency : 50 - 160 Hz
- Vertical sync. polarity : positive or negative
- Horizontal frequency : 30 to 82 kHz
- Horizontal sync. polarity : positive or negative
- Resolution : up to 1280x1024 at
76 Hz refresh rate
: up to 1600x1280 at
60 Hz refresh rate
- Misconvergence : 0.3 mm in the center
0.5 mm in the corners

Preset modes

- Number of preset modes : 22 (14 factory
presets)

* Technical data are subject to change without notice

Technical data

Factory Preset Video Timings

Item	Unit	1280*1024 64kHz / 60Hz		640*350 VGA mode 1		640*400 VGA mode 2		640*480 VGA mode 3		800*600 S-VGA std.	
		1	2	3	4	5					
Mem. channel	No.	107.3	25.175	25.175	25.175	35.86					
Pixel rate	MHz	63.9	31.468	31.468	31.468	35.16					
Hor. freq.	kHz	60	69.93	69.93	59.94	56.25					
Vert. freq.	Hz	1280	640	640	640	800					
Hor. resol.	dots	1024	350	400	480	600					
Vert. resol.	H	1680	800	800	800	1020					
Period (hor.)	dots	400	160	160	160	220					
Blanking	dots	30	16	16	16	24					
Sync delay	dots	108	96	96	96	72					
Sync width	dots	N	N	N	N	N					
Interlace	Y/N	N	N	450	525	625					
Period (vert)	lines	41	100	50	45	25					
Blanking	lines	3	37	12	10	1					
Sync delay	lines	3	2	2	2	2					
Sync width	lines	3	N	N	N	N					
Sync on green	Y/N	Y	N	-	-	+					
TTL H sync	±		+	+	-	+					
TTL V sync	±		-	+	-	+					
TTL comp sync	±										
Hor. width	mm/20° mm/21°	340/20° 356/21°	350/20° 380/21°	350/20° 380/21°	350/20° 380/21°	350/20° 350/21°					
Vert. width	mm/20° mm/21°	272/20° 285/21°	263/20° 285/21°	263/20° 285/21°	263/20° 285/21°	263/20° 263/21°					

Item	Unit	800*600 S-VGA		XGA		640*480 MacIcx		800*600 VESA 1		1024*768 VESA 2	
		6	7	8	9	10					
Mem. channel	No.	40	44.9	30.25	50	65					
Pixel rate	MHz	37.88	35.52	35.0	48.077	48.36					
Hor. freq.	kHz	60.3	87/43.5	66.7	72.187	60					
Vert. freq.	Hz	800	1024	640	800	1024					
Hor. resol.	dots	600	384/768	480	600	768					
Vert. resol.	H	1056	1264	864	1040	1344					
Period (hor.)	dots	256	240	224	240	320					
Blanking	dots	40	8	64	56	25					
Sync delay	dots	128	176	64	120	136					
Sync width	dots	N	Y	N	N	N					
Interlace	Y/N	N	409	525	666	806					
Period (vert)	lines	28	25	45	66	38					
Blanking	lines	1	0/0.5	3	37	3					
Sync delay	lines	4	4	3	6	6					
Sync width	lines	4	N	N	N	N					
Sync on green	Y/N	N	N	N	N	N					
TTL H sync	±	+	+	-	+	+					
TTL V sync	±	+	+	-	+	+					
TTL comp sync	±										
Hor. width	mm/20° mm/21°	350/20° 380/21°	350/20° 380/21°	350/20° 380/21°	350/20° 380/21°	350/20° 380/21°					
Vert. width	mm/20° mm/21°	263/20° 285/21°	263/20° 285/21°	263/20° 285/21°	263/20° 285/21°	263/20° 285/21°					

Item	Unit	1024*768 VESA 3		1152*870 69kHz / 75Hz		832*624 50kHz / 75Hz		1280*1024 81kHz / 76Hz	
		11	12	13	14				
Mem. channel	No.	75	100	57.28	135				
Pixel rate	MHz	56.47	68.68	49.7	81.13				
Hor. freq.	kHz	70.07	75	75.18	76.1				
Vert. freq.	Hz	1024	1152	832	1280				
Hor. resol.	dots	768	870	624	1024				
Vert. resol.	H	1328	1456	1152	1664				
Period (hor.)	dots	304	304	320	384				
Blanking	dots	24	32	32	32				
Sync delay	dots	136	128	64	104				
Sync width	dots	N	N	N	N				
Interlace	Y/N	N	915	667	1066				
Period (vert)	lines	38	45	43	42				
Blanking	lines	3	3	1	2				
Sync delay	lines	6	3	3	8				
Sync width	lines	6	N	N	N				
Sync on green	Y/N	N	N	-	-				
TTL H sync	±	+	-	-	-				
TTL V sync	±	+	-	-	-				
TTL comp sync	±								
Hor. width	mm/20° mm/21°	350/20° 380/21°	350/20° 380/21°	350/20° 380/21°	340/20° 356/21°				
Vert. width	mm/20° mm/21°	263/20° 285/21°	263/20° 285/21°	263/20° 285/21°	272/20° 285/21°				

2. Connection facilities

Pin assignment 15p "D" shell
(3 rows)

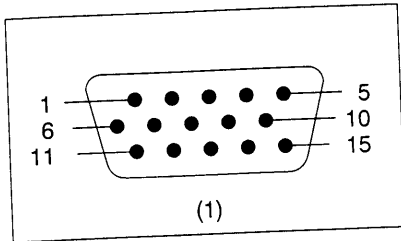

Pin assignment 15p "D" shell
(2 rows)

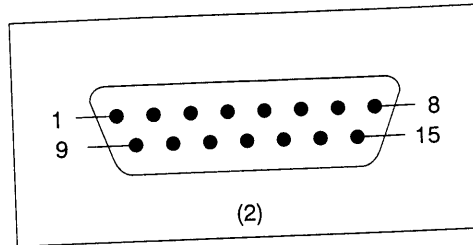

CL36532020/020
200193

INPUT- OUTPUT SIGNALS

15 pins D-Shell connector

D-Shell adapter (3 rows to 2 rows)

Pin	Assignment	Sensitivity	Terminal Impedance	Assignment	Sensitivity	Terminal Impedance
1	Red Video input	RGB-analog	75Ω	Red ground		
2	Green Video input/ sync. on green	RGB-analog	75Ω	Red Video input/ Composite sync.	RGB-analog	75Ω
3	Blue Video input	RGB-analog	75Ω	Sense 0		2.2 kΩ
4	Ident output (connected to 10)			Green Video input (Sync. on green)	RGB-analog	75Ω
5	Self test input (ground)			Green ground		
6	Red Video ground			Sense 1		
7	Green Video ground			Not connected		
8	Blue Video ground			Blue Video input	RGB-analog	75Ω
9	Not connected (no pin)			Sense 2		
10	Logic ground			Comp-sync and V-sync ground		
11	Ident output (connected to 10)			V-sync		
12	Not connected			Blue Video ground		
13	Horizontal sync. (or Hor. + Vert. sync)	TTL Level L=0-0.8V H=2.4 -5V	2.2 Ωk pull down			
14	Vertical sync.	TTL Level L=0-0.8V H=2.4 -5V	2.2 Ωk pull down	H-sync ground		
15	Not connected (no pin)			H-sync		

3. Warnings and Notes

Warnings

1. Safety regulations require that the unit should be returned in its original conditions and that components identical to the original components are used. The safety components are indicated by the symbol **▲**.
2. In order to prevent damage to **ICs** and transistors, all high-voltage flash-overs must be avoided. In order to prevent damage to the picture tube, the method shown in Fig. 3.1 should be used to discharge the picture tube. Use a high-voltage probe and a multimeter (position DC-V). Discharge until the meter reading is **0 V** (after approx. 30s).

3. ESD **▲**

All **ICs** and many other semiconductors are sensitive to electrostatic discharges (ESD). Careless handling during repair can drastically shorten the life. Make sure that during repair you are connected by a pulse band with resistance to the same potential as the earth of the unit. Keep components and tools also at this same potential.

4. When repairing a unit, always connect it to the mains voltage via an isolating transformer.
5. Be careful when taking measurements in the high-voltage section and on the picture tube panel.
6. It is recommended that safety goggles are worn when replacing the picture tube.
7. When making settings, use plastic rather than metal tools. This will prevent any short-circuit and the danger of a circuit becomes unstable.
8. Never replace modules or other components while the unit is switched on.
9. Together with the deflection unit the picture tube is used as an integrated unit. Adjustment of this unit during repair is therefor not recommended.
10. After repair the wiring should be fastened once more in the cable clamps for this purpose.

Notes

1. The semiconductors indicated in the circuit diagram(s) and in the parts lists are completely interchangeable per position with the semiconductors in the unit, irrespective of the type indication on these semiconductors.
2. The direct voltages and oscillograms are average voltages. They have been measured by using the service test software and under the following conditions:
 - Signal pattern : grey scale.
 - Mode: VGA (640 * 480) 31,5kHz/60Hz.
 - Contrast and Brightness to maximum.

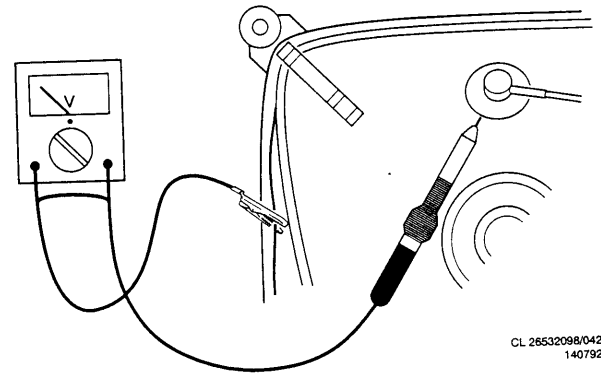

CL 26532098/042
140792

Fig. 3.1

4. Mechanical instructions

General

To be able to perform measurements on the circuit boards, the unit should be placed in the service position first. For the location of the circuit boards and the item numbers mentioned in this chapter we refer to the exploded view drawing.

Rear cover, item 101

- Remove the screws , item 112 (4x)
- The rear cover can now be removed.

Top screening, item 37

- Loosen the crews item 24 (5x) a few turns.
- The screening can now be removed by sliding it back wards.

Screening left, item 5

- Loosen the screws item 8 (3x) a few turns.
- The screening can now be removed by swinging it to the left side.
- The PCB boards, "Main Panel", "Horizontal Sync. Panel", "Low Signal Panel" and "Degaussing Panel" are than reachable.

Screening right, item 51

- Loosen the screws item 8 (3x) a few turns.
- The screening can now be removed by swinging it to the right side.
- The PCB Board, " Supply Panel" is then reachable.

Rear screening with input sockets, item 11

- Remove the screws item 10 (9x)
 - The screening with input sockets can now be pulled backwards.
- Remark: By leaving the wire trees connected, the monitor is still working.
- The PCB Boards, "Video Panel", "Video Interface Panel" and CRT Panel are than reachable.

Abbreviations

ABBREVIATIONS

AA1200V	: HORIZONTAL DEFLECTION YOKE (HOT)
AA200V/AE200V	: JUMPER ON H DEF. SUPPLY VOLTAGE
ABL	: BEAM CURRENT INDICATION FOR BEAM LIMITER CIRCUIT (-1V/0.1mA)
AG200	: HORIZONTAL DEFLECTION YOKE
BAL/PAR.IN	: BALANCE PARALLELOGRAM INPUT
BCCE	: BUFFERED CONVERGENCE CHIP ENABLE
BCCE0	: BUFFERED CONVERGENCE CHIP ENABLE 0
BCCE1	: BUFFERED CONVERGENCE CHIP ENABLE 1
BC OUT	: BUFFERED CLOCK CONVERGENCE DATA OUT
BCK	: BUFFERED CLOCK
BDIN	: BUFFERED DATA INPUT
BDOUT	: BUFFERED DATA OUTPUT
BHOR	: BUFFERED HORIZONTAL SYNC
BLANK	: LOGICAL BLANK SIGNAL ACTING ON HVP SIGNAL (ACTIVE HIGH)
BLD	: BUFFERED LOAD
BLP	: BUFFERED PAR ALLEL LOADS
BRXD	: BUFFERED RECIEVER DATA
BRIGHT	: DC NEGATIVE VOLTAGE FOR G1 CONTROL (BRIGHTNESS)
BSTB	: BUFFERED STROBE
BTXD	: BUFFERED TRANSMITTER DATA
BVER	: BUFFERED VERTICAL SYNC
CCE	: CONVERGENCE CHIP ENABLE
CDOUT	: CONVERGENCE DATA OUT
CLAMP	: BACKPORCH SIGNAL FOR VIDEO AMP. DC RESTORATION
CLK	: CLOCK SIGNAL
COMP	: COMPENSATION
DATA-IN	: SERIAL DATA SIGNAL FOR THE MC14410 DACs
DATA-OUT	: SERIAL DATA OUT
DATA-V	: SERIAL DATA FOR VIDEO DACs
DATIN	: SERIAL DATA INPUT
DATOUT	: SERIAL DATA OUTPUT
DC.V.CONV	: DC VERTICAL CONVERGENCE
DC.V.HEIGHT	: DC VERTICAL HEIGHT
DC.H.WIDTH	: DC HORIZONTAL WIDTH
DC.H.SHIFT	: DC HORIZONTAL SHIFT
DEGAUSS	: ONE-SHOT SIGNAL FOR DEGAUSSING CIRCUIT
DEL-ST	: DELAYED STROBE FOR S-CORRECTION CAPACITOR LOADING
DF OUT	: DYNAMIC FOCUS OUTPUT
DIN-	: SERIAL DATA TO LOGIC BOARD
DOUT	: DATA OUT
E	: ENABLE
EN1/EN2	: COMPLEMENTARY SIGNAL FOR VIDEO INPUT SELECTION (ACTIVE HIGH)
E/W-KEY IN	: EAST/WEST KEYSTONE INPUT
GATE	: SIGNAL AT HALF VERTICAL FREQ. FOR PERIOD MEASUREMENT
H1	: D-SUB HORIZONTAL OR COMPOSITE SYNC INPUT
HD	: DRIVE SIGNAL FOR HORIZONTAL OUTPUT STAGE
H.DC-SHIFT	: HORIZONTAL DC SHIFT
H-DRIVE	: HORIZONTAL OSCILLATOR OUTPUT
HFL	: HORIZONTAL RETRACE PULSE (FROM POWER STAGE)
HFLY	: HORIZONTAL FLYBACK VIDEO
H-H+V	: BNC HORIZONTAL OR COMPOSITE SYNC INPUT
H-H+V-S	: SELECTED HORIZONTAL OR COMPOSITE SYNC
HOR	: HORIZONTAL SYNC (TO LOGIC BOARD)
H-PHASE	: DC CONTROL FOR HORIZONTAL OSCILLATOR PHASE ADJUSTMENT
HV-EN	: ENABLE SIGNAL FOR HIGH VOLTAGE GEN. (ACTIVE HIGH)
HV-ON	: HIGH VOLTAGE STATUS INDICATION (+5V IF ON)
HVP	: DEFLECTION FAIL SIGNAL ACTING ON G1 CIRCUIT (ACTIVE LOW)

H.CONV : DC CONTROL FOR HORIZONTAL STATIC CONVERGENCE
H.CONV.F : FEEDBACK FROM HORIZONTAL STATIC CONVERGENCE AMPLIFIER
H.DC SHIFT : DRIVE SIGNAL FOR RASTER CENTERING
H.FAIL : HORIZONTAL DEFLECTION STATUS (+5V IF ON)
H.LIN-FB : FEEDBACK FROM HORIZONTAL LINEARITY COIL
H.LIN-OUT : DC CONTROL FOR HORIZONTAL LINEARITY COIL
H.STATIC : HORIZONTAL CONVERGENCE OUTPUT
LD : LAOD
LDAC : LOAD SIGNAL FOR GEOMETRY DAC,S
LOCKPLL : HORIZONTAL OSCILLATOR STATUS INDICATION
N.C. : NOT CONNECTED
NOSYNC : HORIZONTAL SYNC STATUS INDICATION
OUT-LOCK : HORIZONTAL OSCILLATOR LOCKED / NOT LOCKED INDICATION
PL : STROBE SIGNAL FOR U806 (PARALLEL LOAD)
POL-HOR : HORIZONTAL SYNC POLARITY INDICATION
POL-VER : VERTICTAL SYNC POLARITY INDICATION
RD : DRIVE SIGNAL FOR HORIZONTAL SUPPLY MODULATOR (V806)
RESBLK : RESET BLANK
RFSS : FLIP-FLOP RESET SIGNAL
RXD : RECEIVE DATA (RS232 PORT)
R.RELE : REED RELAIS CONNECTION FOR TERMINATION SWITCH
R/G/B GAIN : DC CONTROL FOR VIDEO AMPLIFICATION
R/G/B IN 1 : BNC VIDEO INPUTS
R/G/B IN 2 : D-SUB VIDEO INPUTS
R/G/B LEVEL : DC CONTROL FOR VIDEO CUT-OFF ADJUSTMENT
R/G/B OUT : VIDEO AMPLIFIERS OUTPUT TO CRT
RSEL : LCD DATA DRIVE (OUTPUT MICROPROCESSOR)
SEROUT : SERIAL OUT
SDO : SERIAL DATA OUT
ST : STROBE SIGNAL
STB : STROBE
STM : STROBE SIGNAL FOR THE MC14410 DACs (LOW LEVEL BOARD)
SW : INPUT SELECTION (BNC/D-SUB) CONTROL
TRMLCD : TRIMMER LCD
TXD : TRANSMIT DATA (RS232 PORT)
V : BNC VERTICAL SYNC INPUT
V1 : D-SUB VERTICAL SYNC INPUT
V-DRIVE : DRIVE SIGNAL FOR THE VERTICAL DEFLECTION OUTPUT STAGE
VDYN : DRIVE SIGNAL FOR VERTICAL DYNAMIC FOCUS AMPLIFIER
VDYNF : FEEDBACK SIGNAL FROM VERTICAL DYNAMIC FOCUS AMPLIFIER
VERT : VERTICAL SYNC (TO LOGIC BOARD)
VF : VERTICAL FLYBACK (CALLED VF1 AFTER THE JUMPER ON YOKE CONN.)
V-PULSE : RAMP GENERATOR DISCHARGE PULSE
V-S : SELECTED VERTICAL SYNC
VY1,VY2 : VERTICAL DEFLECTION YOKE
V.BLK : SIGNAL FOR VERTICAL RETRACE SUPPRESSION
V.DYN.CON.1 : VERTICAL CONVERGENCE FEEDBACK (FROM NECK TWIST COIL)
V.DYN.CON.2 : VERTICAL CONVERGENCE DRIVE
V.FAIL : VERTICAL DEFLECTION STATUS
V.SYNC : VERTICAL SYNC (AFTER PASSING SYNC PROCESSING CIRCUIT)
Y.CONV.F.B. : VERTICAL CONVERGENCE FEEDBACK
Y.CONV.IN : VERTICAL CONVERGENCE INPUT
V.PAR.OUT : VERTICAL PARABOLA OUT
Y.SAWT OUT : VERTICAL SAWTOOTH OUT
V.SHIFT : VERTICAL SHIFT
WR : WRITE

For Service Manuals
MAURITRON SERVICES
8 Cherry Tree Road, Chinnor
Oxfordshire, OX9 4QY.
Tel (01844) 351694
Fax (01844) 352554
email:- mauritron@dial.pipex.com

WIRING DIAGRAM

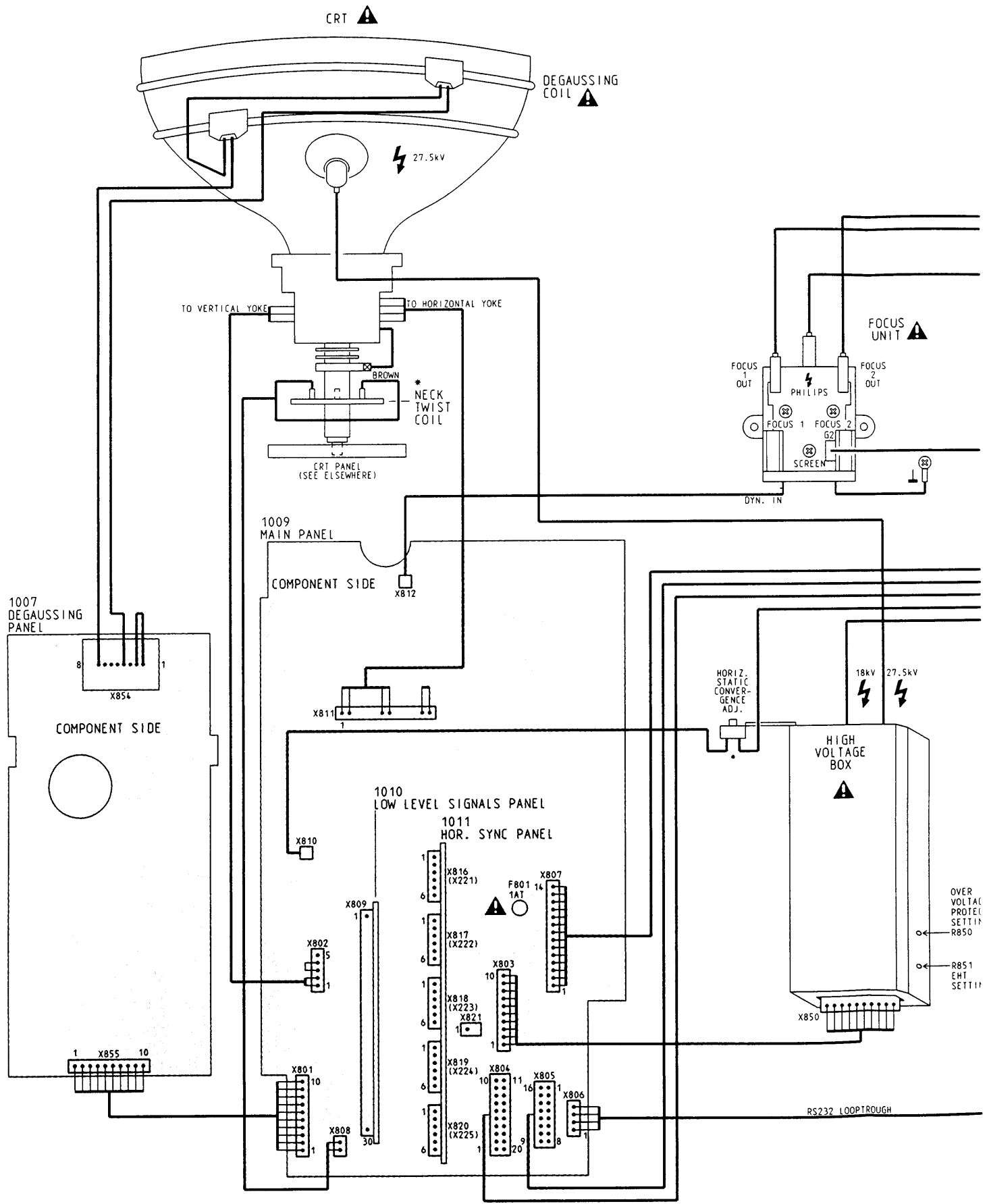

• ONLY FOR C20820AS/BA

Wiring diagram

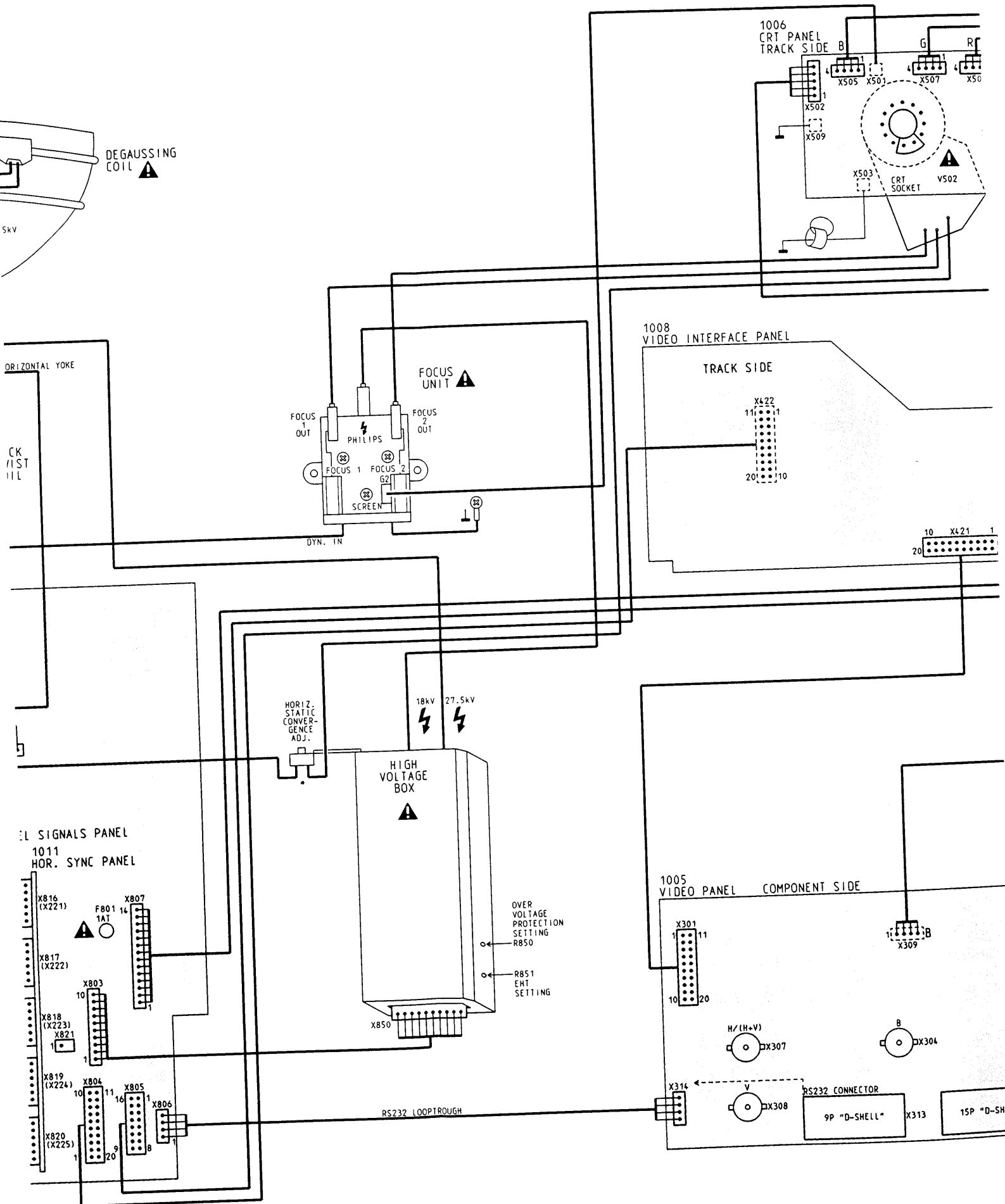

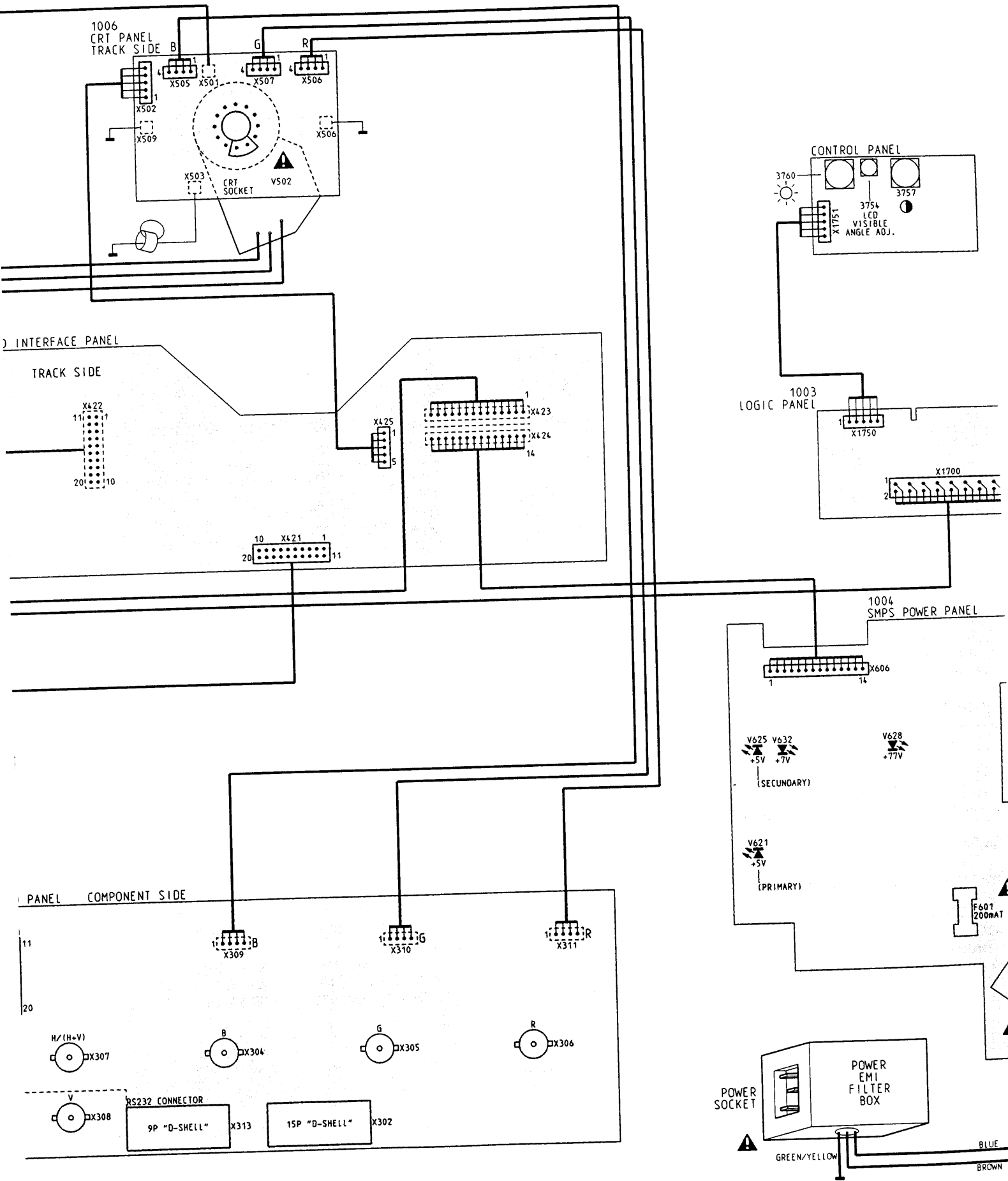

Wiring diagram

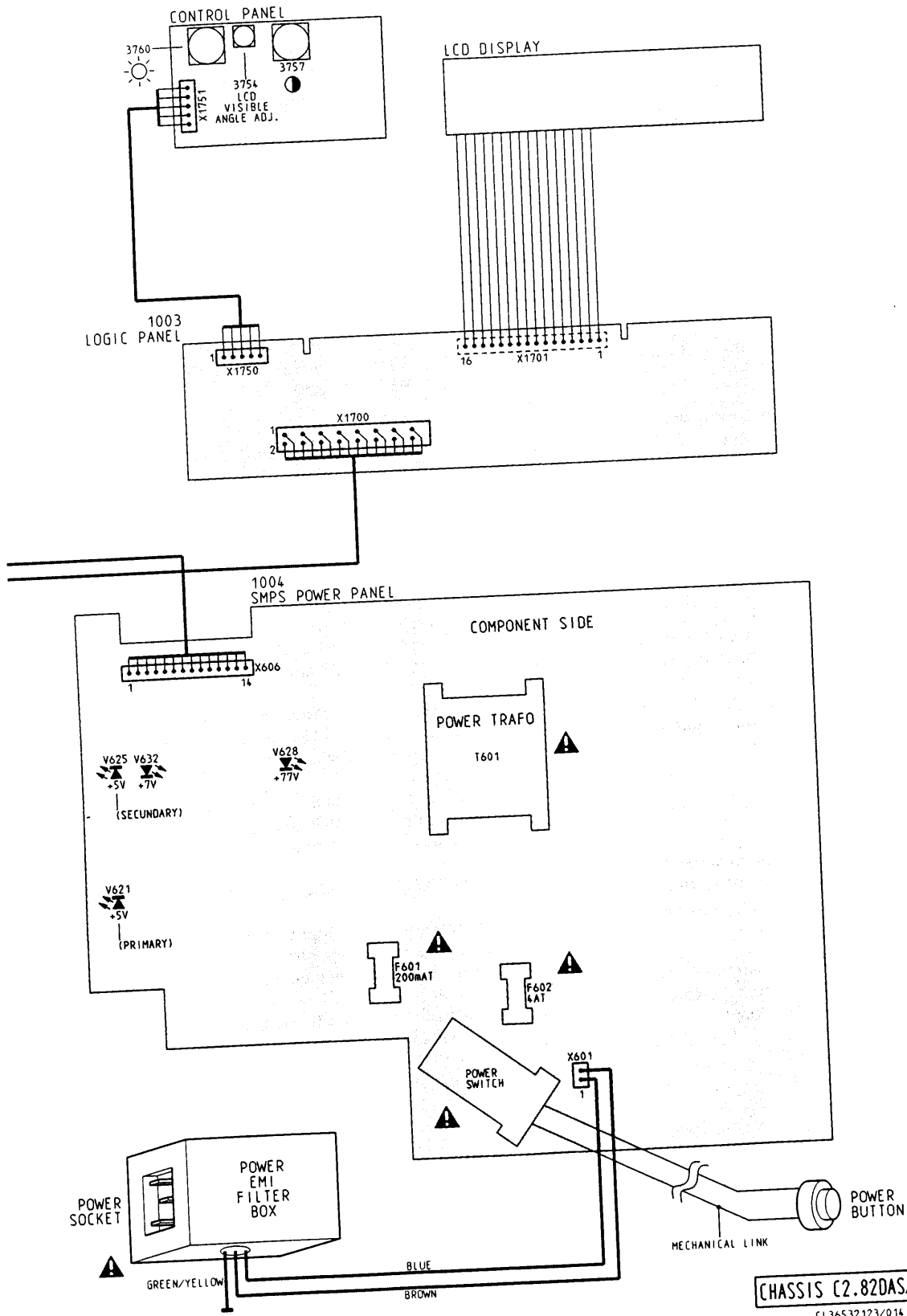

CHASSIS C2.82DAS/II

CL36532123/014.X001
100993

Functional block diagram

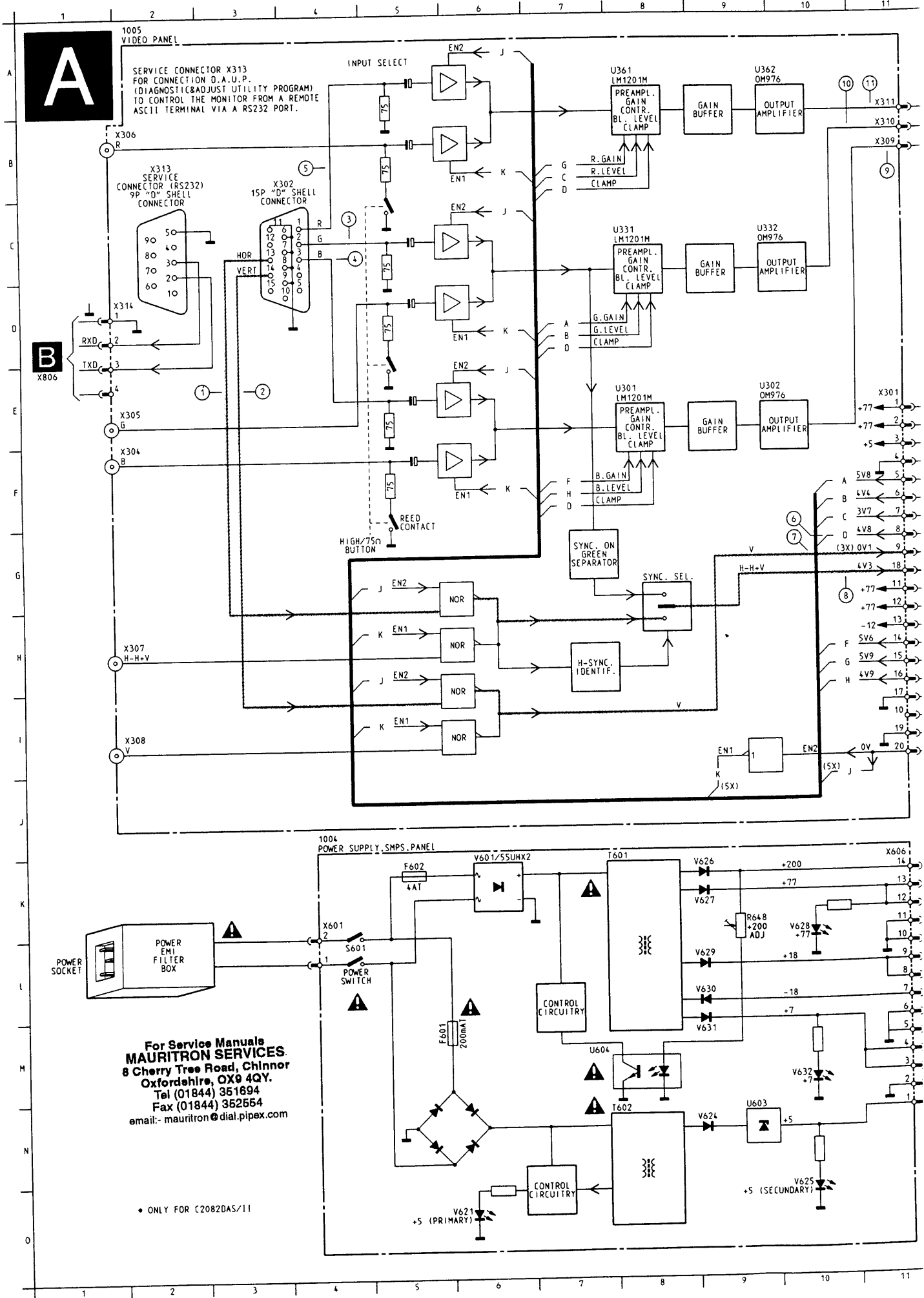

For Service Manuals
MAURITRON SERVICES
8 Cherry Tree Road, Chinnor
Oxfordshire, OX9 4QY.
Tel (01844) 361694
Fax (01844) 362664
email:- mauritron@dial.pipex.com

• ONLY FOR C2082DAS/11

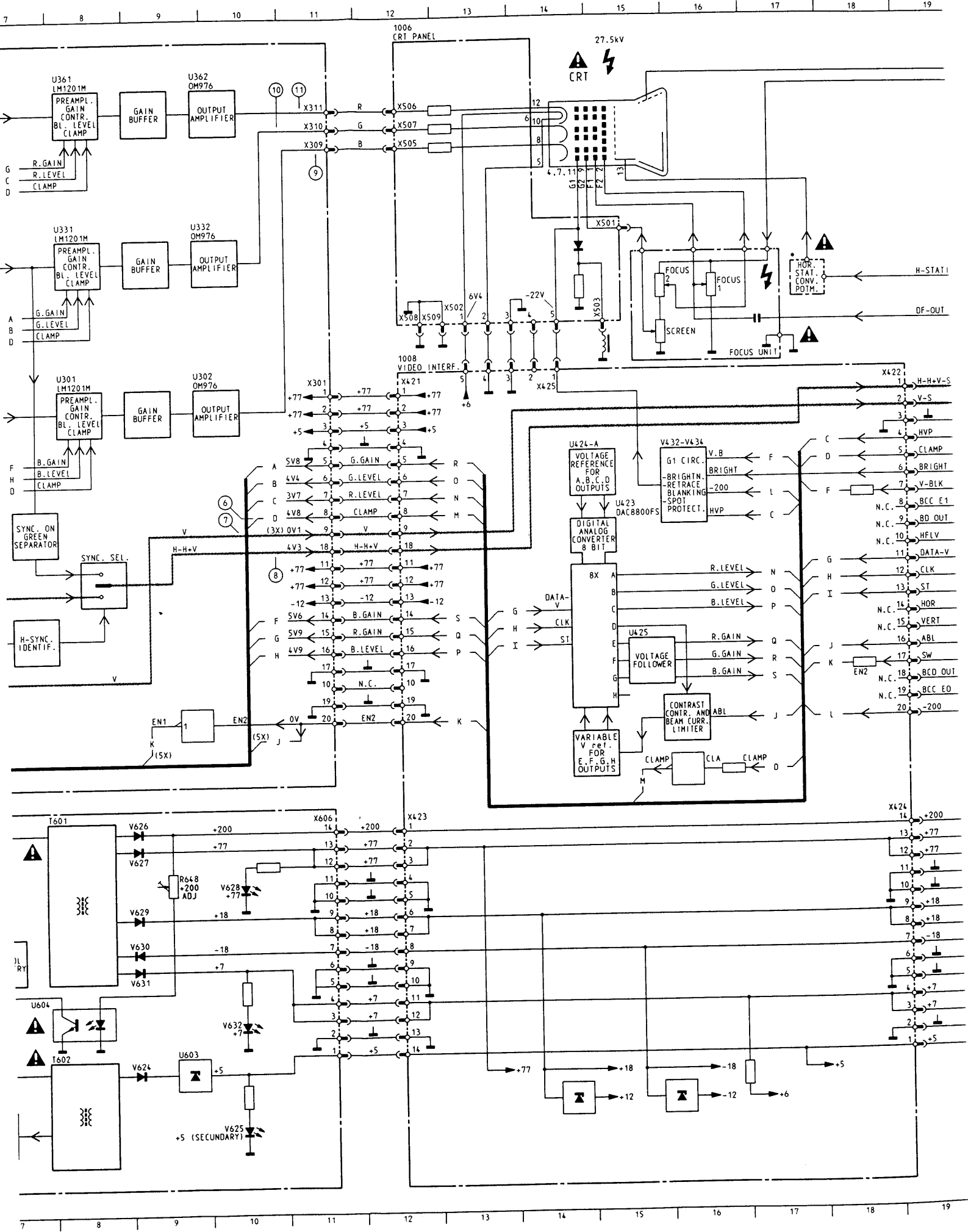

Block diagram

Functional block diagram

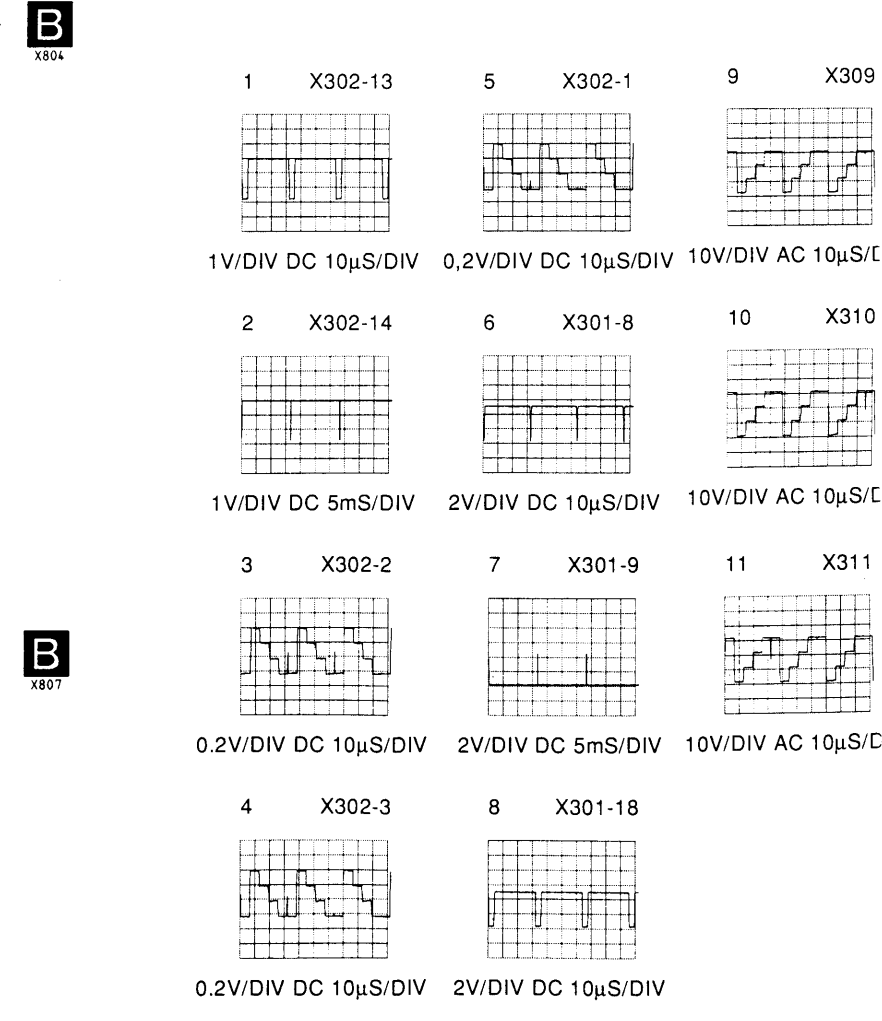
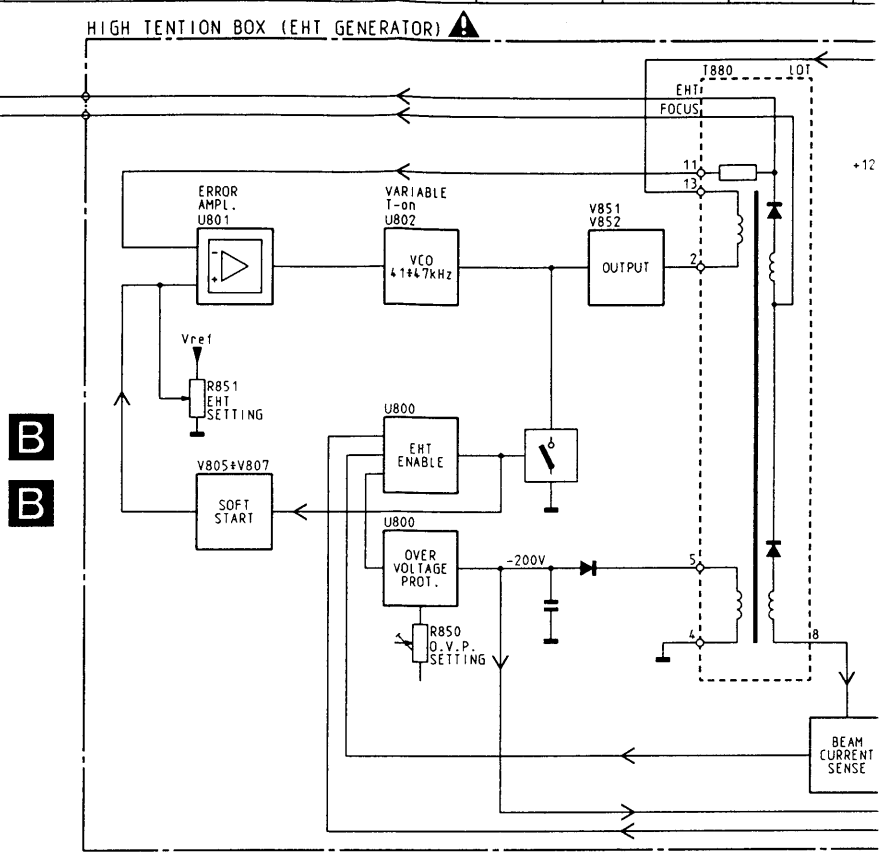
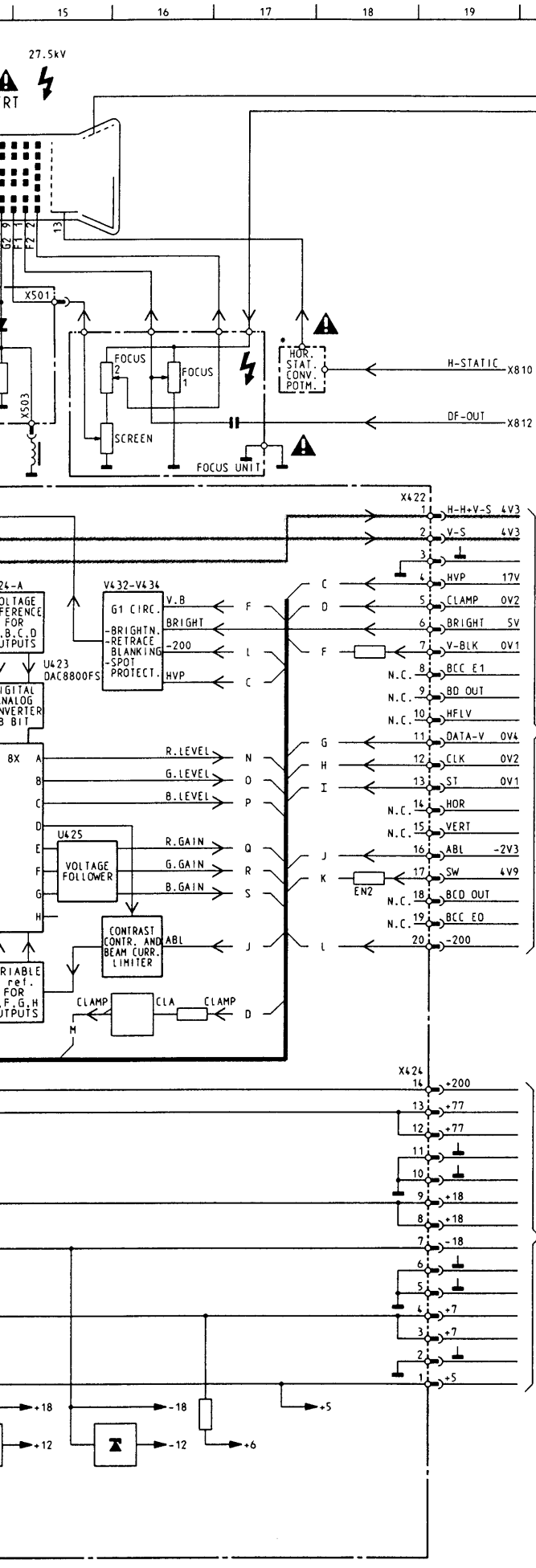

Functional block diagram

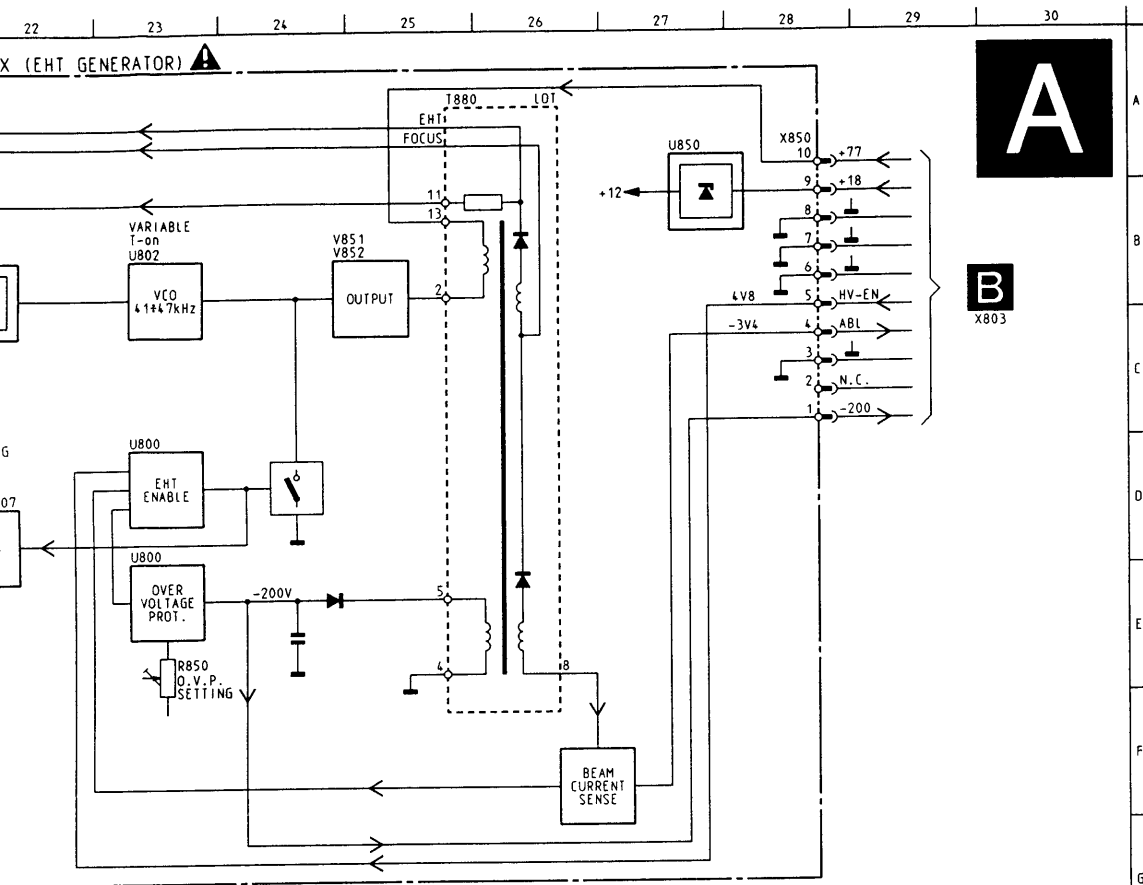

A

B
X803

X302-13

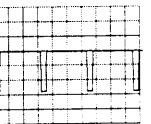

10V/DIV DC 10μS/DIV

5

X302-1

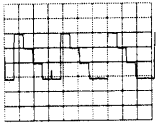

0,2V/DIV DC 10μS/DIV

9

X309

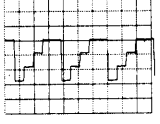

10V/DIV AC 10μS/DIV

2

X302-14

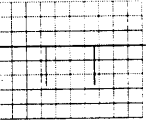

10V/DIV DC 5mS/DIV

6

X301-8

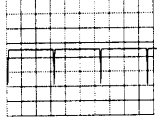

2V/DIV DC 10μS/DIV

10

X310



10V/DIV AC 10μS/DIV

3

X302-2

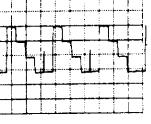

10V/DIV DC 10μS/DIV

7

X301-9

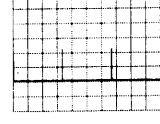

2V/DIV DC 5mS/DIV

11

X311



10V/DIV AC 10μS/DIV

4

X302-3



10V/DIV DC 10μS/DIV

8

X301-18

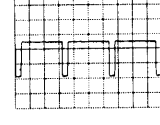

2V/DIV DC 10μS/DIV

CHASSIS C2.82DAS/11

CL36532123/011,AREF
100993

Functional block diagram

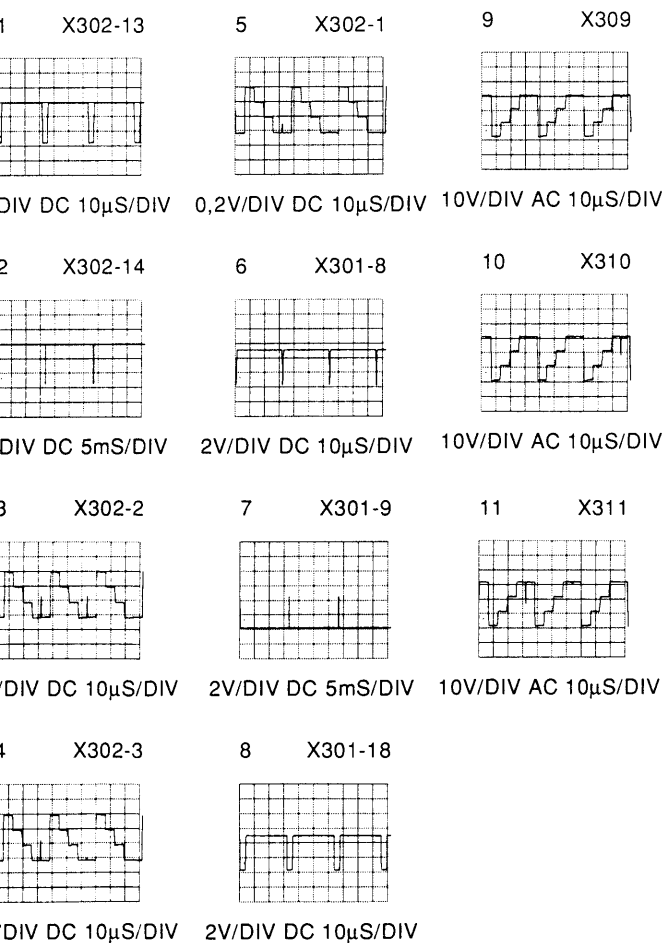
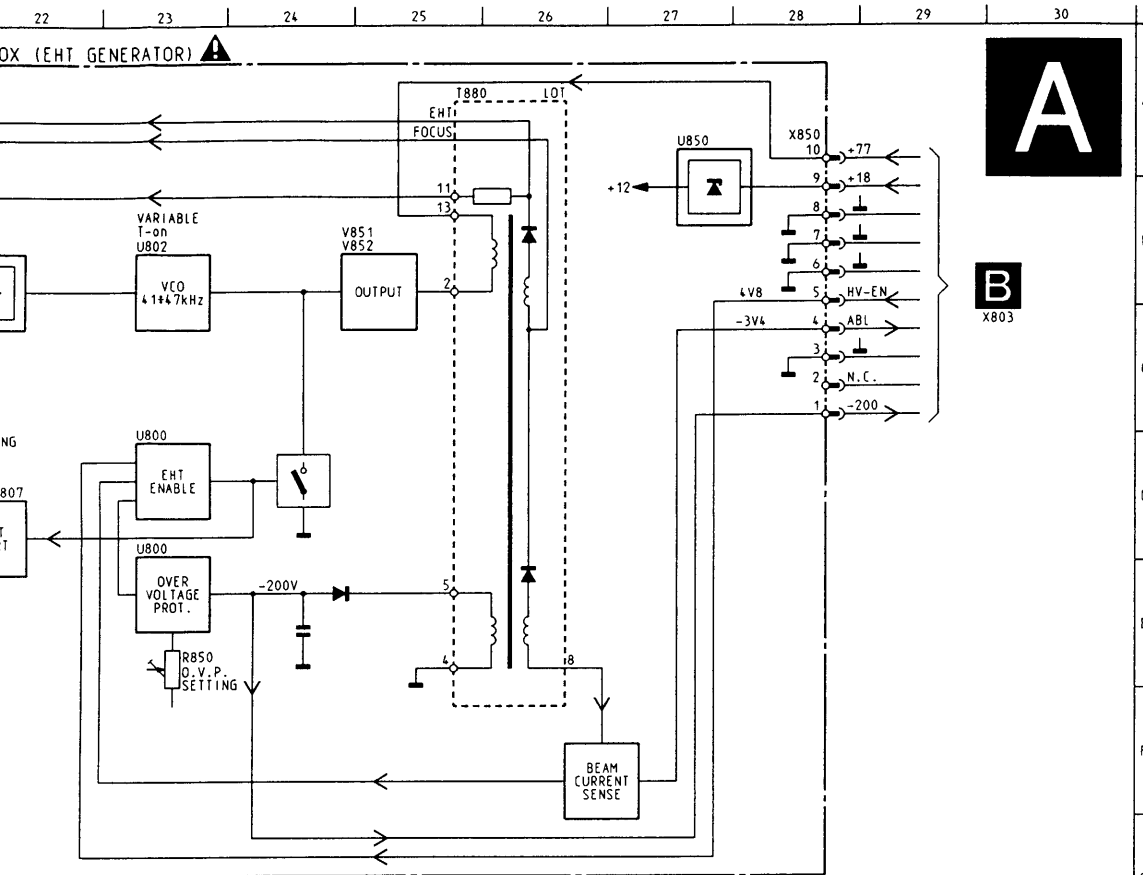

CHASSIS C2.82DAS/11

CL 36532123/011, AREF 100993

Functional block diagram

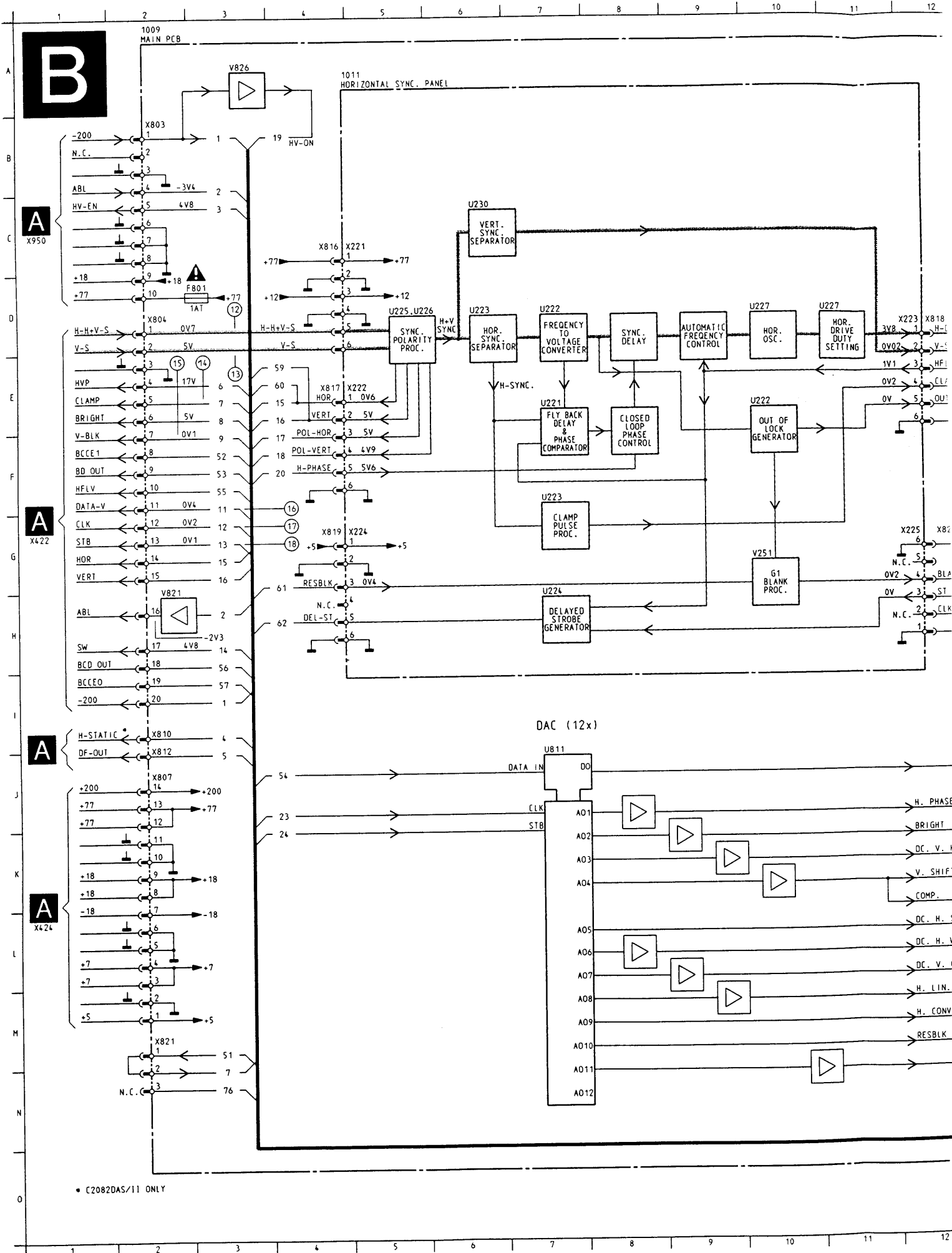

• C2082DAS/11 ONLY

Functional block diagram

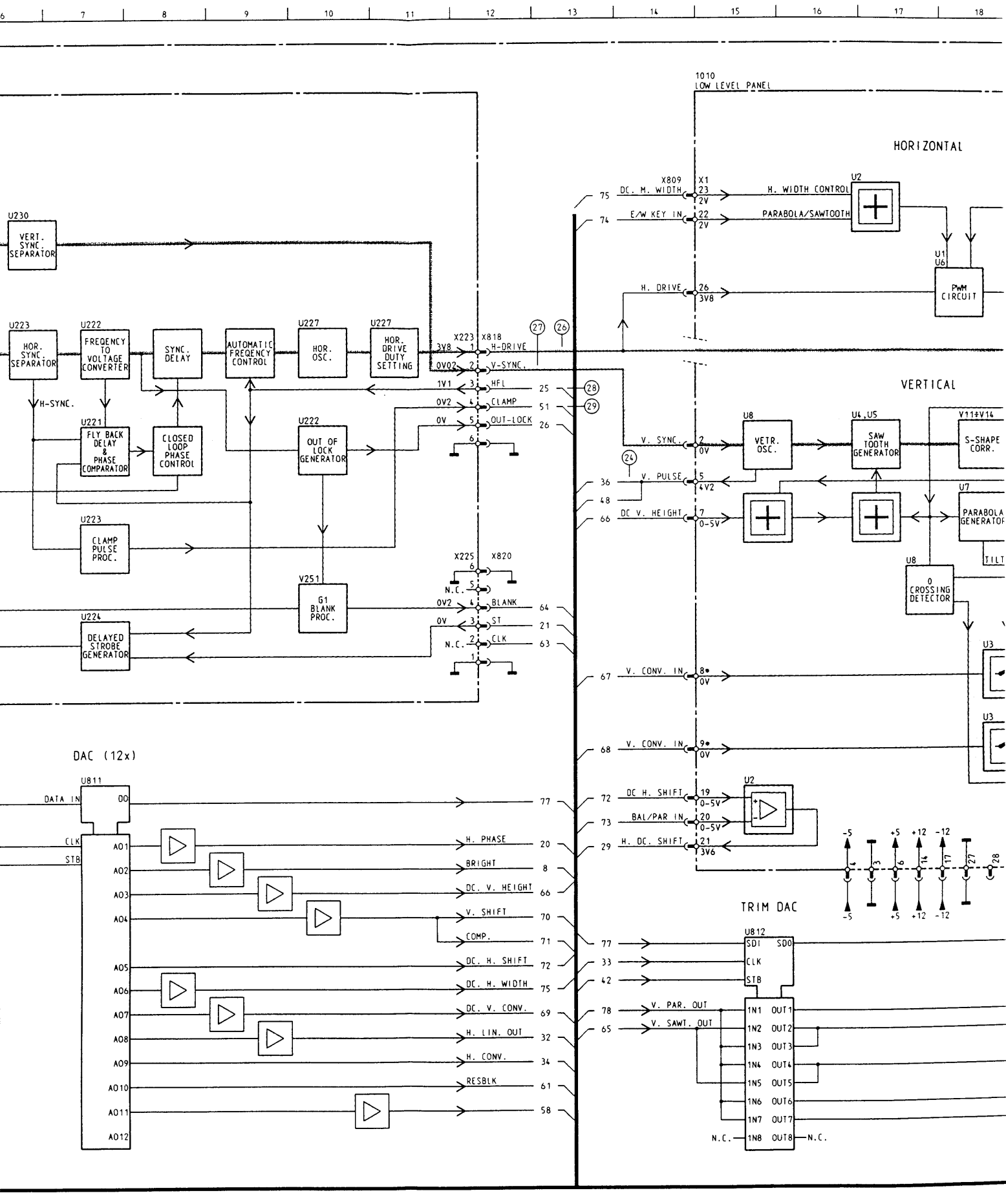

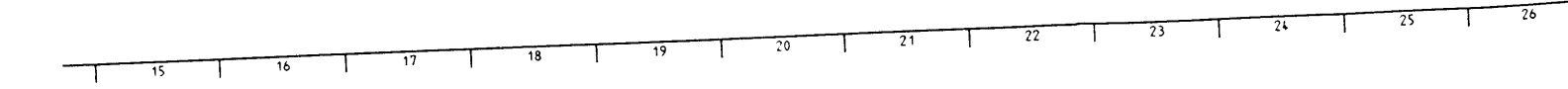
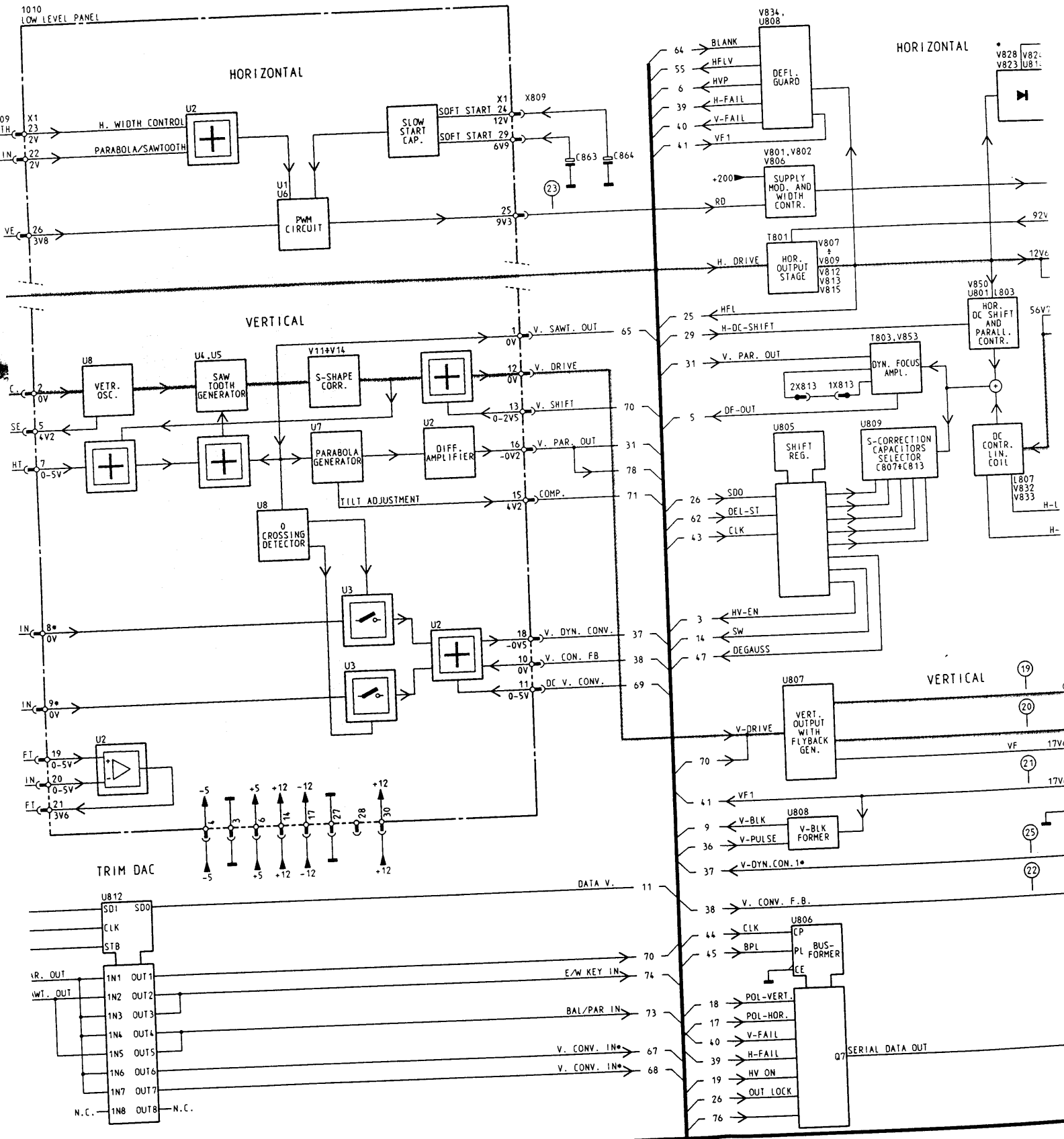
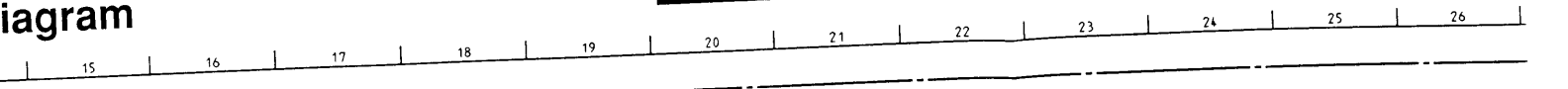

Functional block diagram

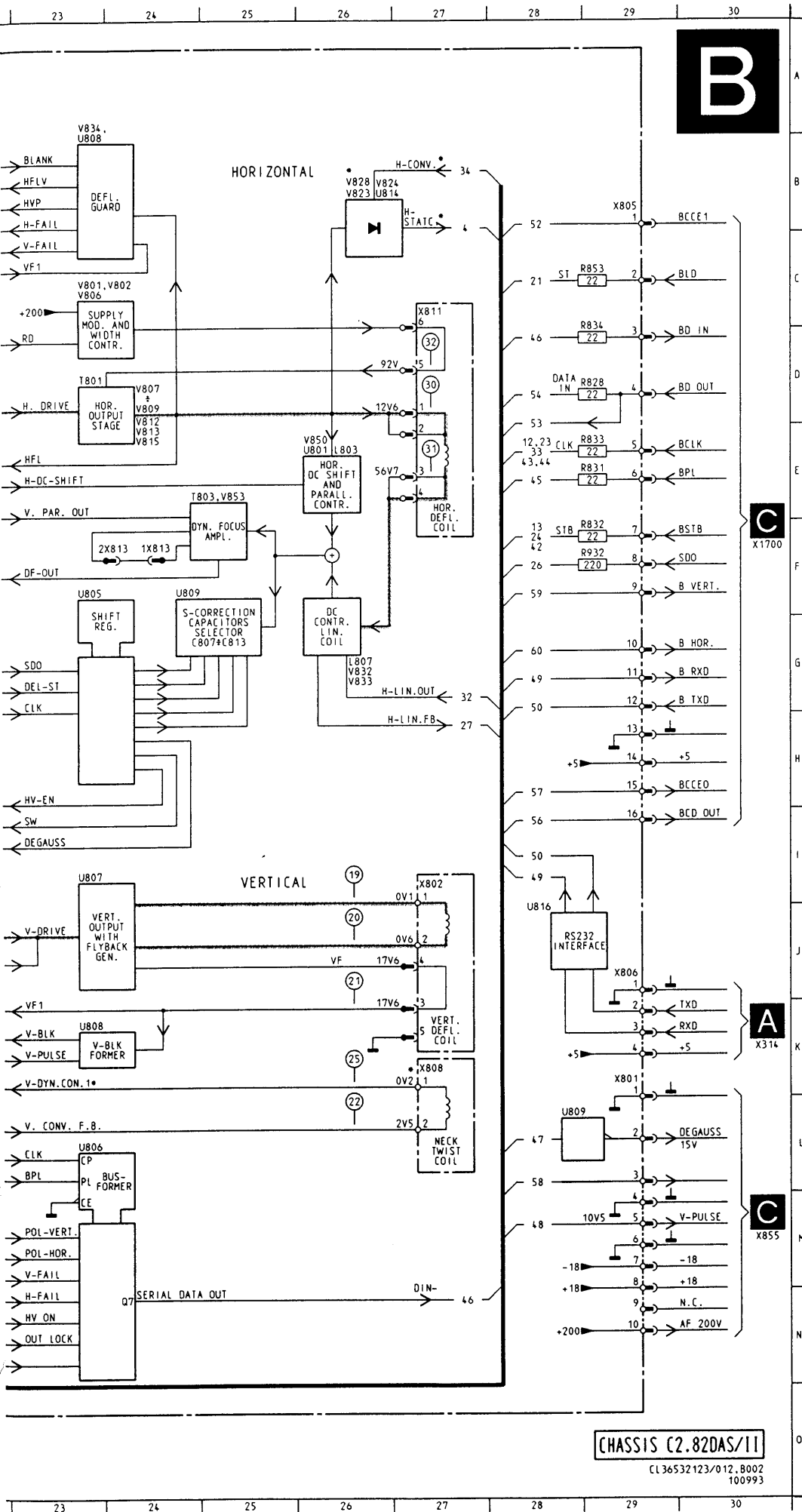

Functional block diagram

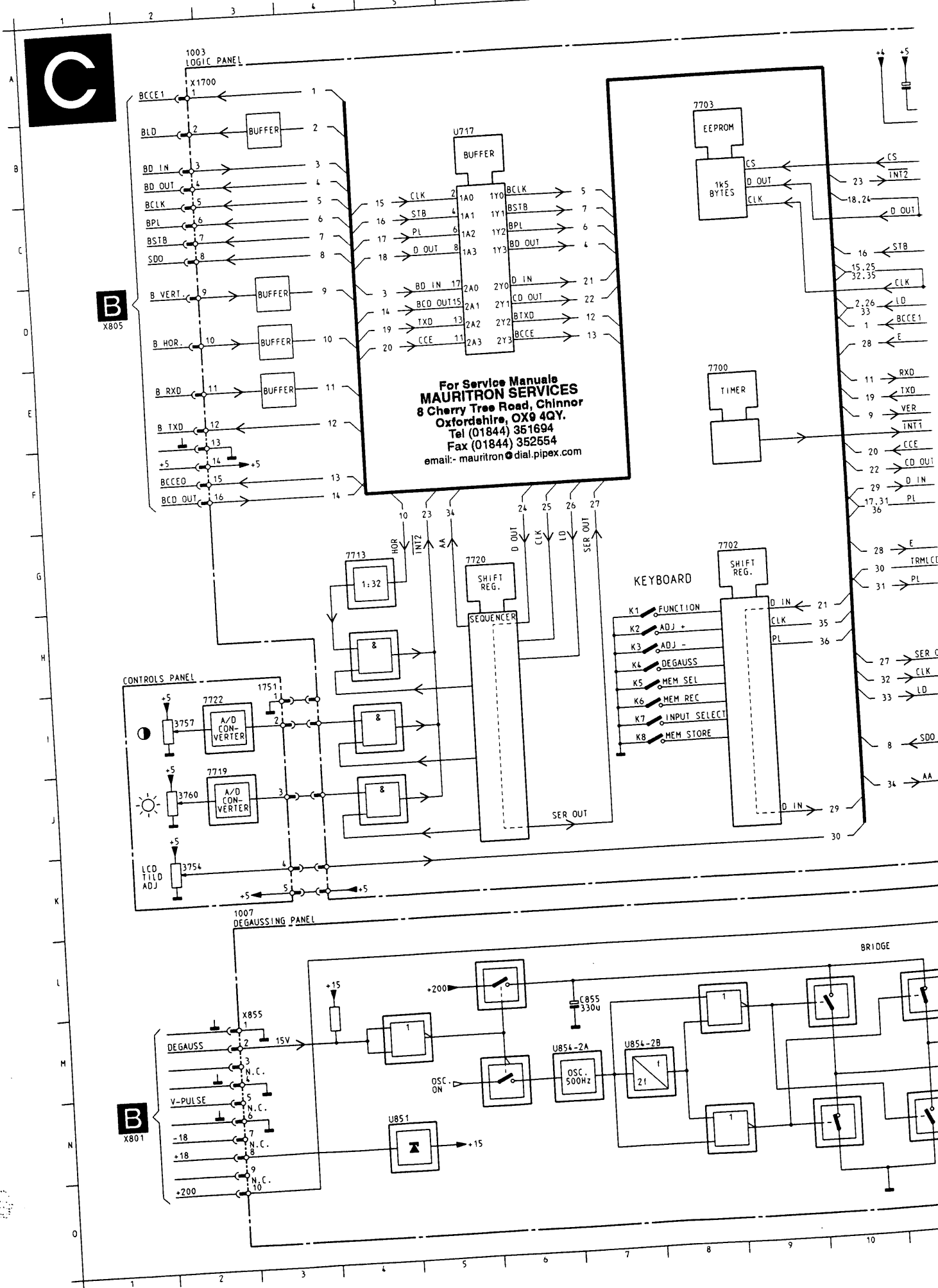

gram

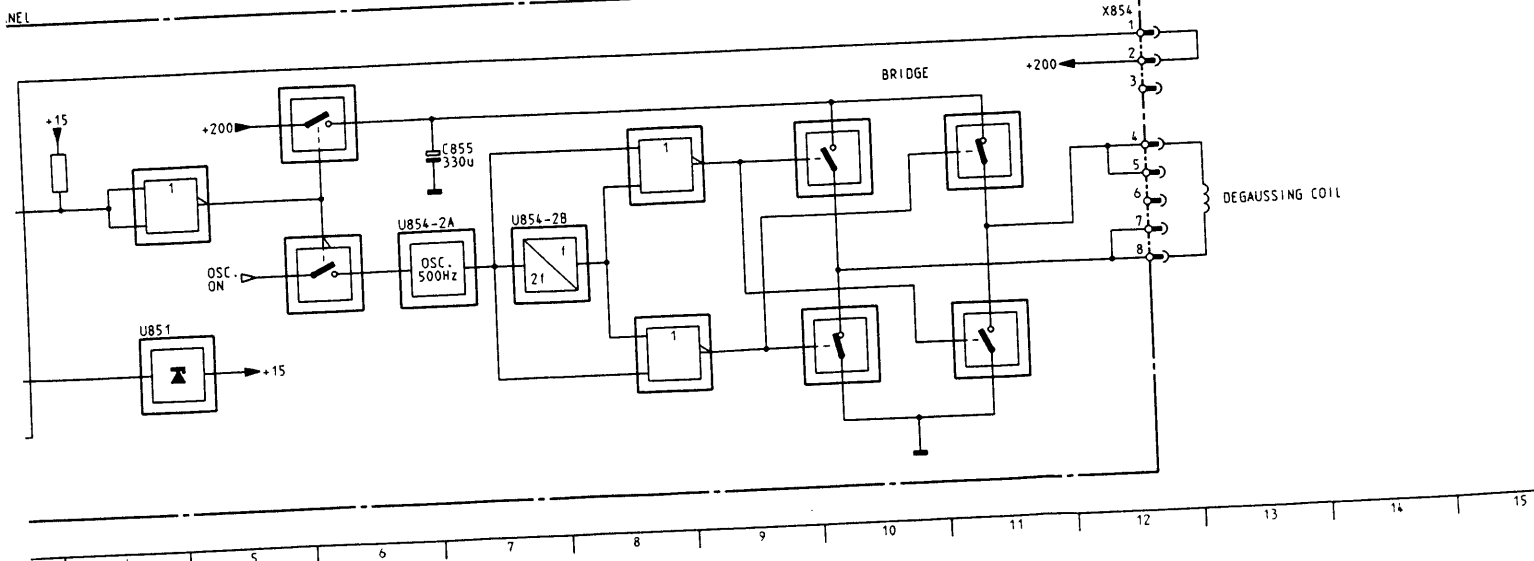
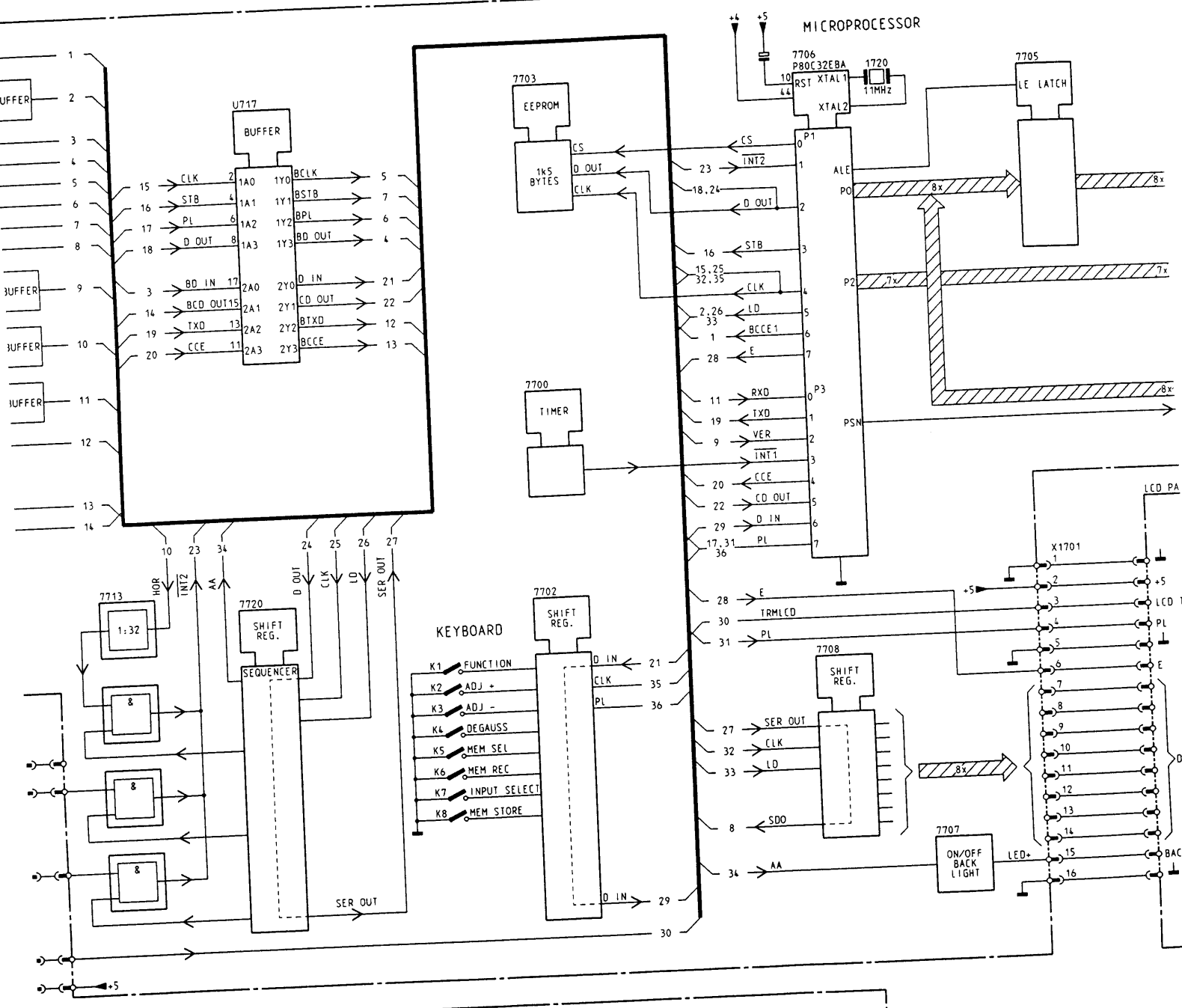

Functional block diagram

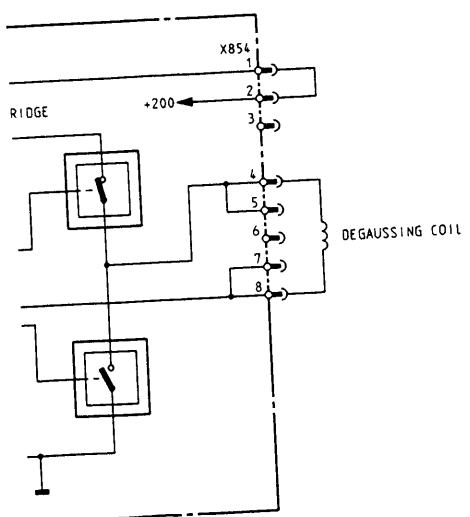
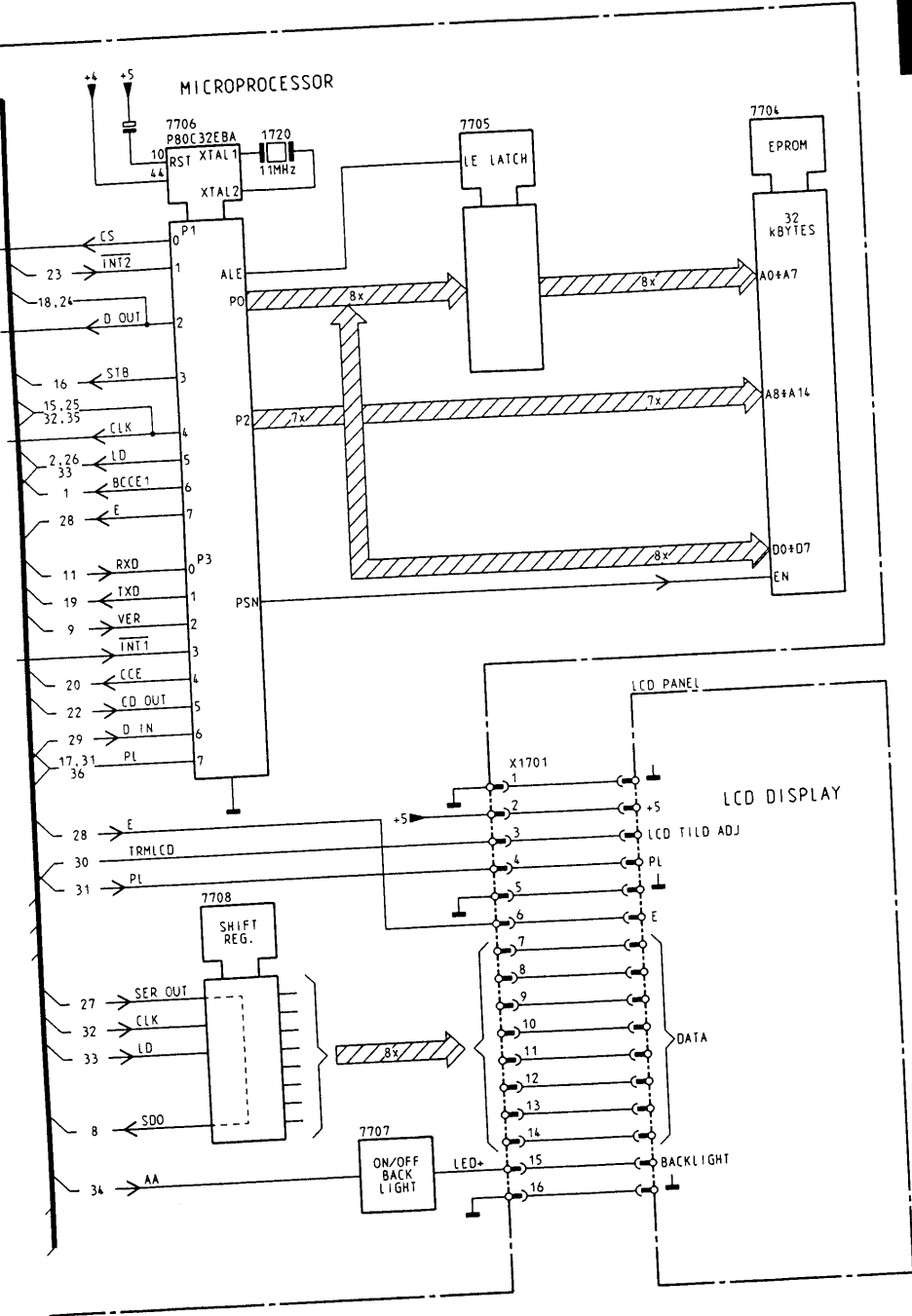

CHASSIS C2.82DAS/11

CL36532123/013.C001
100993

Wave forms diagram B and C

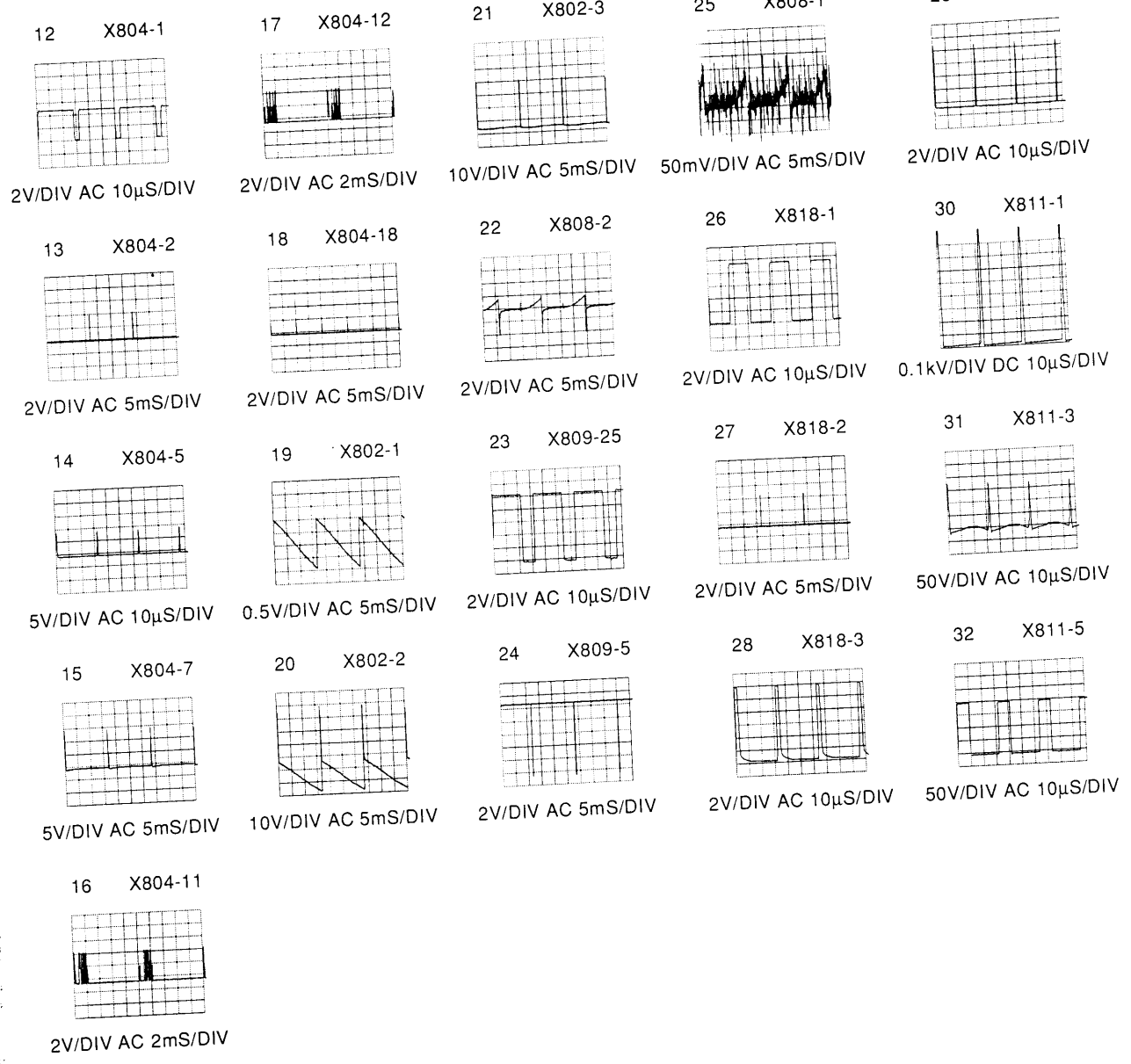

7. Electrical adjustments

ADJUSTMENTS NEEDED AFTER REPLACEMENT OF A F.R.U. (FIELD REPLACEMENT UNIT)

General

In general, after swap a board (F.R.U.), no service adjustments are necessary. Only in some worst case situations and after CRT replacement readjustments have to be executed. Due to the fact that nearly all adjustments as chromaticity, geometry and convergence are controlled via the soft-ware program of the internal microcomputer and not can be changed by the external keys, external software for readjustments is available. This test software available on floppy can be applied to the monitor via a computer with RS232 output port. Also a standart 9 pin "D-shell female" to 9 pin "D-shell male" connection cable (service code 4822 321 21988) is needed to connect the computer to the 9 pin "D-shell" socket (female) at the rear of fthe monitor on the Video Panel. The service code number for the floppy with printed user guide is 4822 727 19992.

1. Logic Panel

Remark: For reason of standardisation the Logic panel listed on parts list is supplied without Eprom item 7704. In case of replacement of the Logic Panel, the original Eprom (if not defect) or a new Eprom can be mounted. For the service code number of the Eprom see also parts list.

- In case of replacement of the logic Panel, there is the possibility to place on the new Panel the EEprom (7703), original mounted on the defective Panel. In that case there is no need to make readjustments, because this EEprom contains all the original monitor set up adjustments.
- If there is not above mentioned possibility, it is necessary to make a new monitor set up, including geometry, chromaticity and memory channels adjustments.
- LCD polarisation (tilt) adjustment, 3754 on control panel
Adjust 3754 for optimum character view.
Remark: 3754 is reachable via a hole in the bottom of the front mask.

2. Power Panel

- No adjustments. R648 (+200 adjustment) is already factory adjusted.

3. Video panel

- Basically no adjustments necessary. But check for sure the chromaticity adjustments.

4. Video interface Panel

- Basically no adjustments necessary. But check for sure the chromaticity adjustments.

5. Degaussing Panel

- No adjustments.

6. Main Panel

- Geometry adjustments

7. High Voltage Box

- No adjustments. R850 (over voltage protection setting) and R851 (EHT setting) are already factory adjusted.

8. C.R.T.

- Geometry adjustments
- Focus adjustments
- Chromaticity adjustments
- Horizontal and Vertical convergence adjustments

8. Repair tips

TROUBLE SHOOTING VIA DISPLAY MESSAGES

PROBLEM

LCD does not turn ON when you turn ON the monitor.

Solution:

- Power cord is not connected to the power source.
- No power in that wall outlet.
- Monitor or fuse are faulty.

PROBLEM

One or two colors are missing.

Solution:

Video signal cables (red, blue or green) have not been connected properly.

PROBLEM

Colored spots appear on the monitor screen (bad colore purity).

Solution:

- Press the degauss button.
- Electromagnetic interference present.
- Move any electromechanical device away from the monitor.

LCD MESSAGE INDICATES - PRESET OFF

It means that the current timing has not been previously stored. The monitor is nonetheless working properly.

Solution:

You may store your timing as a new preset mode on this channel or continue working.

LCD MESSAGE INDICATES - H SYNC OFF or V SYNC OFF or H & V SYNC OFF

It means that the video cable connections are not properly made.

Solution:

See sheet "connection facilities"

If the problem is not solved please check your graphic card.

Please verify the "input selection".

LCD MESSAGE INDICATES - V OUT OF RANGE

It means that the monitor does not recognize the vertical frequency of your graphic board.

Solution:

Please verify that your graphic card operates within the 50 to 160 Hz range of your monitor.

LCD MESSAGE INDICATES - H OUT OF RANGE

It means that the monitor does not recognize the horizontal frequency of your graphic board.

Solution:

Please verify that your graphic card operates within the 30 to 82 kHz range of your monitor.

LCD MESSAGE INDICATES - PLL UNLOCKED

It means that the logic board inside the monitor is defective.

LCD MESSAGE DISPLAYS - V DEF. FAILURE

It means that there is a local failure in the vertical deflection.

LCD MESSAGE DISPLAYS - H DEF. FAILURE

It means that there is a local failure in the horizontal deflection.

LCD MESSAGE DISPLAYS - HI VOL. FAILURE

It means that there is a local failure in the high voltage generator.

LCD MESSAGE DISPLAYS - GEN. FAILURE

It means that 2 or more failures have been detected at the same time.

TROUBLE SHOOTING BACKGROUNDS

When you are facing a problem, first of all try to understand which kind of problem it is and where it is coming from.

If you can see a picture on the screen, usually you should be able to understand the problem looking at the screen itself and take the appropriate corrective actions. When you find a problem looking at the screen, before changing any PCB, check if it is possible to solve the problem by readjusting the related controls. Many times, when you see the picture, the problem is not real failure but only a misadjustment since in most cases of failure (or uncorrect operation) a protection circuit will blank the screen.

The monitor has a built in self diagnostic test performed by the Logic board which is able to check if some important circuits are properly working, such as deflections, EHT, and in case of failure an error message is displayed on the front panel LCD. Additional diag. indicators are the LED placed on the Power supply.

By following the herebelow procedure, you should be able to find the defective board to be replaced.

A) AFTER TURNING THE MONITOR ON, THE CRT IS BLANKED BUT THE LCD IS LIGHTED.

- This means that the mains power is connected and the separated +5V switch mode power supply is working.
At this moment, you should read on the LCD one of the following error messages:

1) H/V or HOR. or VERT. SYNC. OFF

- This means that the displayed type of sync. is missing; check the connections between monitor & video generator and check if the selected video input (BNC's or D-SUB) is the right one.
If everything seems to be OK, check the internal cabling between Video, Video Interface, Main & Logic board. If the cabling is OK, the Video board is suspected to be failed.

2) H.DEF. FAILURE

- This means that the horizontal deflection is missing, nevertheless the vertical deflection is working and so the power supply output short circuit protection hasn't been activated.
In this case you should check the deflection yoke connection (X811) and if all the supply voltages, especially the +200V, are present on the Main board (X807).
If all seems to be OK, the Main board is suspected.

3) V.DEF. FAILURE

- Same meaning and procedure as point 2).

4) HI.VOL. FAILURE

- This means that the High Voltage that supplies the CRT is missing, nevertheless both horizontal & vertical deflections are properly working.
In this case, first of all try to recover the problem by switching the monitor off and on again because the overcurrent protection of the High Voltage generator could be activated by a flashover discharge or really by a too high beam current (for example if the video input termination switch is in the wrong position);

if this does not solve the problem, check the connection between the High Voltage generator box and the fuse F801 placed on the Main board. If all seems to be OK, the High Voltage generator is suspected.

5) GEN.(general) FAILURE

- This means that at least two of the above mentioned failures have been detected at the same time. It can happen when a local failure cause a short circuit on one or more supply voltages, activating in this way the protection of the power supply so that also the non-failed circuits cannot work or when the power supply itself is bad, or when a supply voltage is missing on the Main board. In this case, you should proceed in this way:

- a) Check the LED placed on the power supply. V621 must be on because if you can see the LCD message the separated circuit which supplies the +5V must be working.
If also the other 3 LEDs are on, means that also the main power supply is working. In this case check if any supply voltage is missing on the Main board (due to the cabling); if not, the Main board is suspected.

if the other 3 LEDs are off or blinking, disconnect the Power supply output connector X606 and check the LED again: if they are still off, the Power supply is suspected.

If they are on, means that with X606 connected the SMPS overcurrent protection is activated because there is a short circuit on one of the supply rails. In this case, plug in again X606 and disconnect one at time the supply connectors of all the other boards, following this order : Degauss board, EHT generator, Main board, Video board, Video Interface board. When the Power supply starts working, the PCB which has been disconnected is bad.

B) AFTER TURNING THE MONITOR ON, THE CRT IS BLANKED AND THE LCD IS OFF

In this case, check the LEDs on the Power supply.

1) All the LEDs are off:

check all the connections between the EMI filterbox, mains switch, main fuse (check the fuse itself) and the Power supply board: if all looks correct, replace the Power supply.

2) Only the LED V621 (+5V indicator) is off:

unplug the power supply connector X606 and check again the LED status

- if it is still off, replace the Power supply
- if it is on, means that there is a short circuit on the +5V line; in this case apply the procedure described at paragraph "GEN FAILURE" indication in order to find the defective board.

3) All the LEDs are on:

check if the +5V supply voltage is present on the Main board (X807) and if the cabling between the Main board itself and the Logic board is correct; if yes, the Logic board and/or the LCD assembly is suspected.

9. Directions for use

Front controls

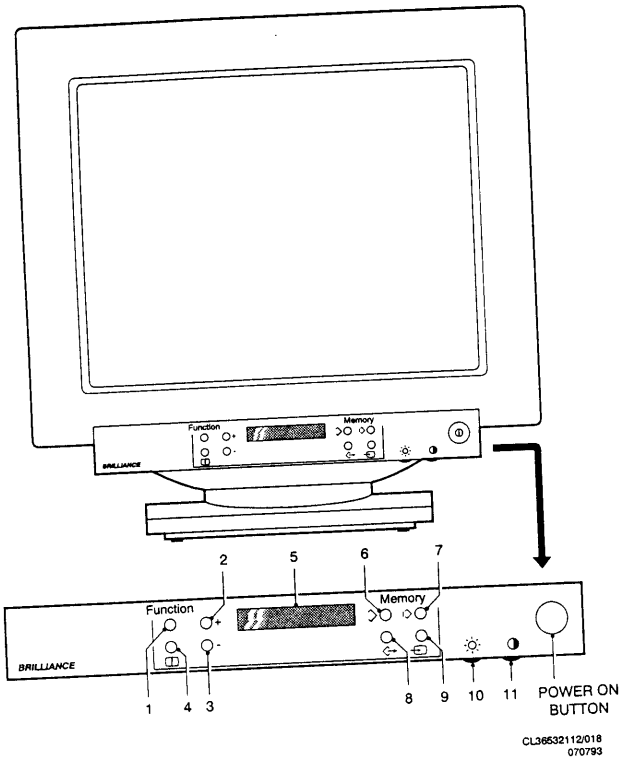

CL38532112/018
070793

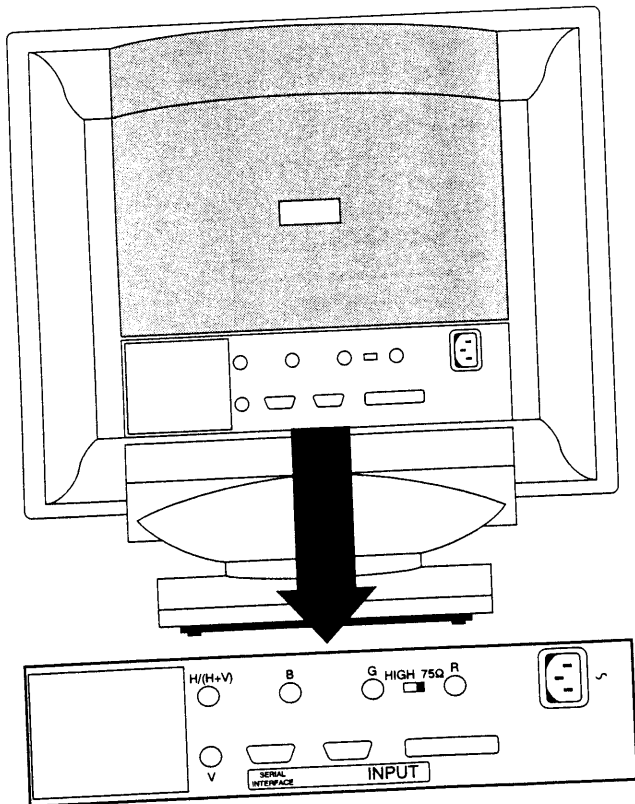

CL38532112/014
060793

- Power button

1 FUNCTION

By pressing repeatedly this button the following parameters can be selected:

- Horizontal phase
- Width
- Vertical shift
- Height
- Vertical convergence*
- Horizontal convergence*
- Color temperature
- Side pincushion
- Pincushion Balance
- Trapezoidal
- Trapezoidal Balance

2 + ADJ

This button allows you to regulate (increase) a chosen parameter. On the LCD an adjustment scale of 0 to 9 will be displayed.

3 - ADJ

This button allows you to regulate (decrease) a chosen parameter. On the LCD an adjustment scale of 0 to 9 will be displayed.

4 Manual Degauss button.

5 LCD display

6 MEMORY SELECT

This button is used to memorize or recall a specified timing.

7 MEMORY STORE.

This button is used to memorize a channel.

8 MEMORY RECALL

The Memory Recall button is used to reset the monitor to the default settings of a specific channel.

9 INPUT SELECT

This button allows you to select the "video input". The options are "BNC" or "D-SUB".

10 - + : Brightness control

11 - + : Contrast control

Rear view

- 5 BNC input connectors
 - * R : red analog video
 - * G : green analog video + combined sync signal.
 - * B : blue analog video
 - * H/H+V : horizontal or composite sync signal.
 - * V : vertical sync signal.
- Mini D-SUB 15 pin connector (Video input)
- Mini D-SUB 9 pin connector (RS232 interface)
- high/75Ω impedance switch
- Power cord connector

* C2082DAS/II and 2020DC only.

For Service Manuals
MAURITRON SERVICES
 8 Cherry Tree Road, Chinnor
 Oxfordshire, OX9 4QY.
 Tel (01844) 351694
 Fax (01844) 352554
 email:- mauritron@dial.pipex.com



V/D'

Connecting the monitor to an IBM PC or compatible with a normal VGA graphics card.

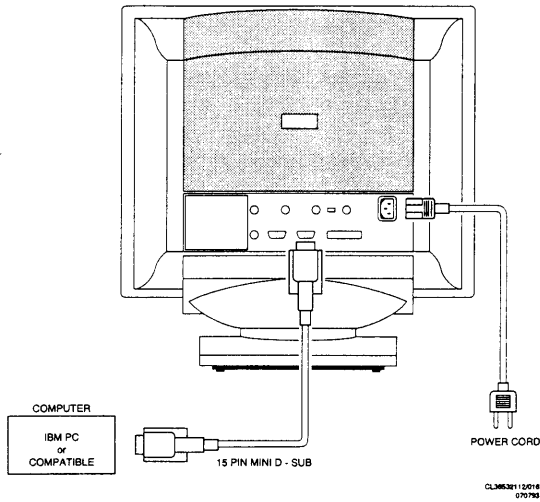

The HIGH/75Ω switch

The switch is used only when you wish to connect more than one monitor to your graphics card. If you are connecting only one monitor to your graphics card, the switch has to be positioned to "75Ω".

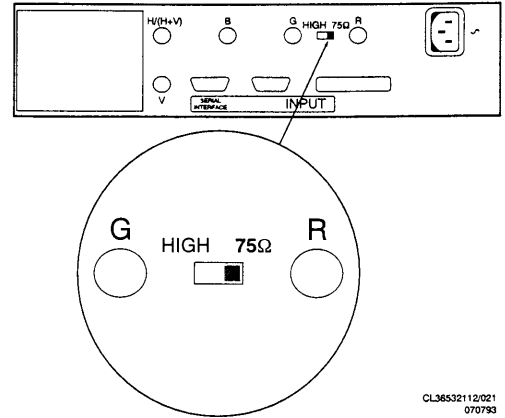

Connecting the monitor to an Apple computer with a MACII video card.

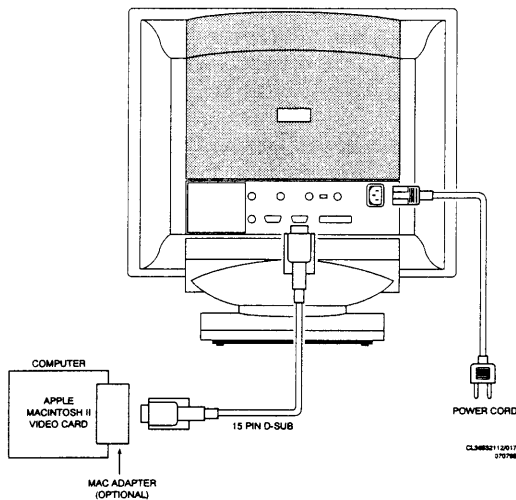

If you are planning to connect more than one monitor to your graphics card, the switch has to be positioned to "high".

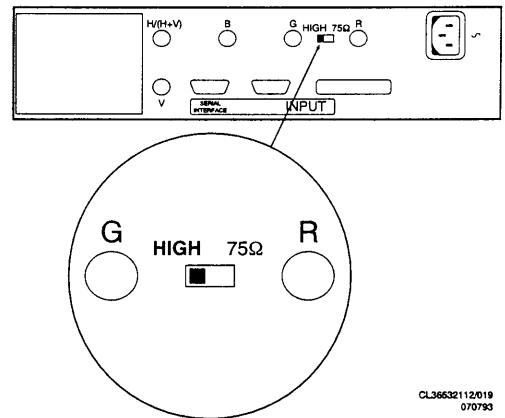

Connecting the monitor to a computer with a high resolution graphics card.

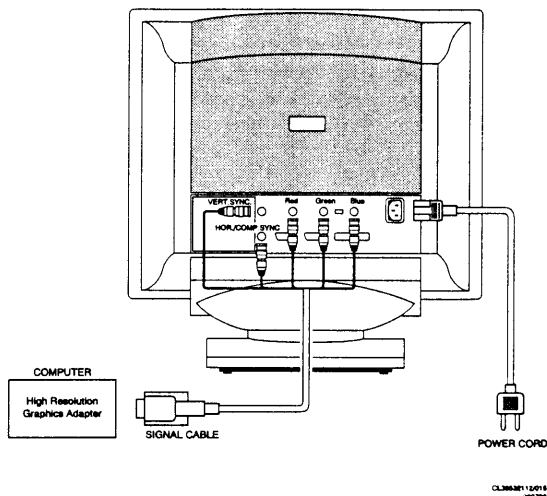

If you are using a "T-BNC" connector to connect 2 monitors together, the last monitor must have the switch in "75Ω" position. Direction for use

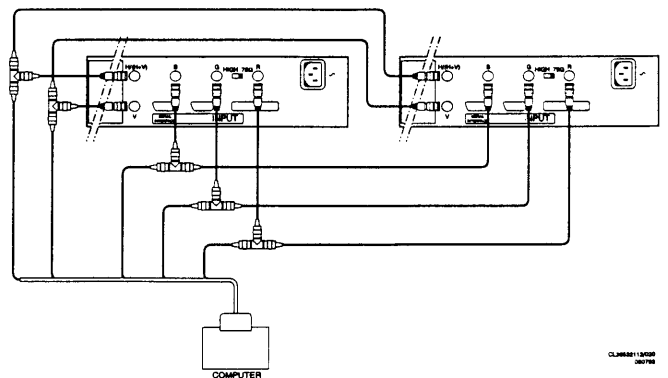

How to use the front controls.

Note: the LCD light will switch itself off automatically after approximately 30 seconds.
By pressing the memory select or function button the LCD light will be switched on.

1. Switch on the monitor

Important: At power on, the LCD will display for 1 to 2 seconds the message "WAIT.... START UP" and then for 1 to 2 seconds the message "F/W Release ..(number)". The message "TEST IN PROGRESS" will also be displayed for 2 to 3 seconds to allow the monitor complete all internal checks. If an error is detected an appropriate message will be displayed. If not, the LCD will display "Mode not Found", which means that the timing displayed is not known to the monitor (i.e. not in the memory). At this stage it is needed to memorize the used timing on a free "preset mode". If the timing used by the computer is already known to the monitor, the LCD will automatically display the "preset mode" that timing is memorized on.

If proper connection is not established within 10 seconds, the LCD will display a "failure message". If there is a problem at this stage please consult the troubleshooting section.

2. FUNCTION button (1)

By pressing repeatedly this button it is possible to select the next parameters;

- horizontal phase
- width
- vertical shift
- height
- vertical convergence *
- horizontal convergence *
- colour temperature
- side pincushion
- pincushion balance
- trapezoidal
- trapezoidal balance

The above mentioned sequence cannot be changed, but it is possible to go backwards by pressing repeatedly the \square "MEM. STORE" button.

The horizontal phase, the width, the vertical shift and the height can be set for each specific channel. All other functions are related to the whole monitor.

2.1 Horizontal phase

A scale of 0 to 9 is available by pressing the "ADJUST buttons". By pressing "-", the hole picture will move horizontally to the left. By pressing "+", the whole picture will move to the right.

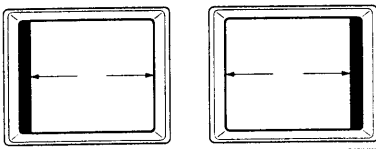

Fig. 2.1

2.2 Width

A scale of 0 to 9 is available by pressing the "ADJUST buttons". By pressing "-", the horizontal width of the picture will be reduced. By pressing "+", the horizontal width of the picture will be enlarged.

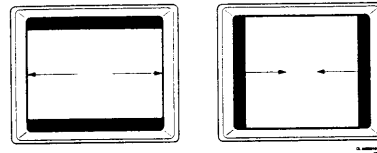

Fig. 2.2

2.3 Vertical shift

A scale of 0 to 9 is available by pressing the "ADJUST buttons". By pressing "-", the picture will move downwards. By pressing "+", the picture will move upwards.

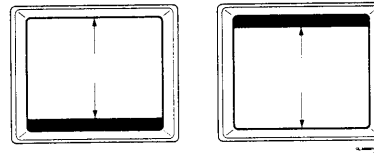

Fig. 2.3

2.4 Height

A scale of 0 to 9 is available by pressing the "ADJUST buttons". By pressing "-", the vertical height of the picture will be reduced. By pressing "+", the vertical height of the picture will be enlarged.

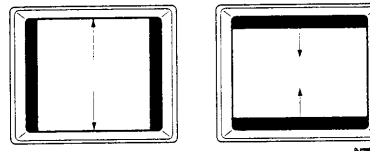

Fig. 2.4

At this stage, if needed to memorize the image settings in a specified "video mode", go to point 5 and 6.

2.5 Vertical convergence*

A scale of 0 to 9 is available by pressing the "ADJUST buttons". By pressing "-" or "+" the convergence of the horizontal lines can be adjusted. With these commands it is possible to move the RED and BLUE beams while the GREEN beam is keeping constant.

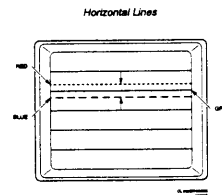

Fig. 2.5

2.6 Horizontal convergence*

A scale of 0 to 9 is available by pressing the "ADJUST buttons". By pressing "-" or "+" the convergence of the vertical lines can be adjusted. With these commands it is possible to move the RED and BLUE beams while the GREEN beam is keeping constant.

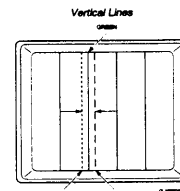

Fig. 2.6

* C2082DAS/II and 2020DC only

2.7 Colour temperature

There are 3 possibilities to change the colour temperature by pressing "ADJUST buttons". The colour temperature 1 is the factory setting at 9300 K° and colour temperature 2 is preset at 6500 K°. The colour temperature 3 can be set by the user;

- a. pressing the "ADJUST buttons" until the LCD displays "Color Temp. 3" and then by pressing the "FUNCTION" button.
- b. "Red Adjust" will be displayed in the LCD; A scale of 0 to 9 is available by pressing the "ADJUST buttons". By using this command it is possible to increase the amount of red displayed in the screen.
- c. press "FUNCTION" again and "Green Adjust" will be displayed in the LCD; A scale of 0 to 9 is available by pressing the "ADJUST buttons". By using this command it is possible to increase the amount of green displayed in the screen.
- d. press "FUNCTION" again and "Blue Adjust" will be displayed in the LCD; A scale of 0 to 9 is available by pressing the "ADJUST buttons". By using this command it is possible to increase the amount of blue displayed in the screen.

If there is a wish to re-adjust any of the above colours just press the "FUNCTION" button. Once you are finished just press (memory select) button to exit these commands.

Important: After a color adjustment, the new control setting will be automatically stored by the monitor within 30 seconds, unless the monitor is switched off, the video mode is changed or the video input selector is changed.

Note: the use of primary colour blue on a dark background is not recommended (bad legibility may cause eyestrain due to low character contrast).

2.8 Side pincushion

A scale of 0 to 9 is available by pressing the "ADJUST buttons". By pressing "-" or "+" it is possible to adjust the pincushion until the right and left side of the picture become linear or straight.

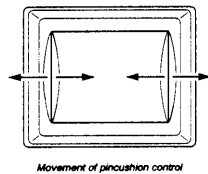

Movement of pincushion control

Fig. 2.8

2.9 Pincushion balance

This control is to be used only when one side of the monitor needs to be adjusted.

A scale of 0 to 9 is available by pressing the "ADJUST buttons". By pressing "-" or "+" it is possible to adjust the picture for a symmetrical distortion. After that it is possible to re-adjust via the pincushion control, see point 2.8 for a linear or straight picture.

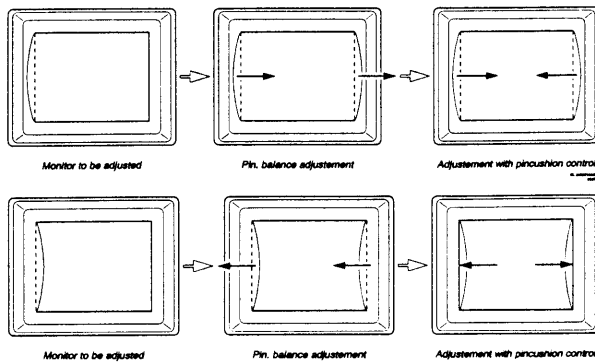
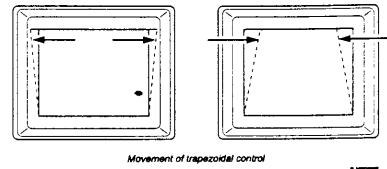

Fig. 2.9

2.10 Trapezoidal

A scale of 0 to 9 is available by pressing the "ADJUST buttons". By pressing "-" or "+" it is possible to adjust the left and right lines as indicated in fig. 2.10



Movement of trapezoidal control

Fig. 2.10

2.11 Trapezoidal balance

A scale of 0 to 9 is available by pressing the "ADJUST buttons". By pressing "-" or "+" it is possible to adjust the left and right lines as indicated in fig. 2.11

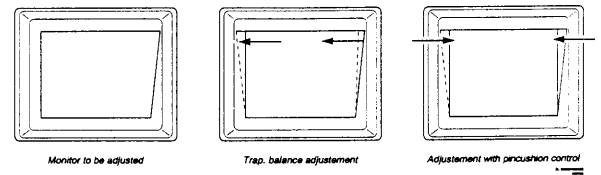

Fig. 2.11

Important: after a geometrical adjustment, the new control setting will be automatically stored by the monitor within 30 seconds, unless the monitor is switched off, the video mode is changed or the video input selector is changed.

2.12. How to recall the original geometry setting

If needed to restore the monitor to its original geometrical specifications, just press the "MEM RCL" button on the front panel. A message on the lcd panel will request a confirmation. Press once again the "MEM RCL." button to complete the operation.

3. + ADJUST (2)

This button allows the user to regulate (increase) a chosen parameter. On the LCD panel an adjustment scale of 0 to 9 will be displayed.

4. - ADJUST (3)

This button allows the user to regulate (decrease) a chosen parameter. On the LCD panel an adjustment scale of 0 to 9 will be displayed.

5. MEMORY SELECT (6)

This button is used to memorize or to recall a specified timing. By pressing "MEM.SEL", the monitor will display the video mode that is presently on. If using a standard resolution which is already present in the monitor, the channel will be pinpointed by the <--- sign (for the complete list see the factory preset video timing table). If on the contrary a resolution is not present, the first available channel will be displayed (from 15 to 21 only). By pressing the "ADJUST buttons" it is possible to change the video mode number for storing the required timing. Please note that is only possible to choice a specific video mode number where to memorize the required timing only with "non factory preset timing". To memorize the changes on a specific video mode just press the "MEM.STORE" button.

6. MEM.STORE button (7)

This button is used to memorize a channel. It must be used in conjunction with "MEM.SEL." to work. Please note that the monitor will not store 2 identical timing.

7. **↔ MEMORY RECALL (8)**

The memory recall button is used to re-set the monitor to the default settings of a specific channel. First select through the "ADJUST buttons" the channel that needs to be restored (valid channels are from 1 to 14), then press "MEM.RCL." button. A message on the LCD display will request a command confirmation, press again "MEM.RCL." to complete the operation.

8. **LCD display (5)**

The Liquid Crystal Display where all the information regarding the front panel control is displayed. there are 3 different types of messages that could be displayed on the LCD;

- a. normal operational messages like the timing displayed etc.
- b. messages related to possible changes in the monitor specifications (adjustment status).
- c. messages related to monitor malfunction or diagnostics.

9. **- ☀ + BRIGHTNESS (10)**

This button is used to adjust the brightness.

10. **- ● + CONTRAST (11)**

This button is used to adjust the contrast.

11. **⊖ INPUT SELECT (9)**

With this button it is possible to select the type of "video input". The options are BNC or D-SUB. If the selected video input is not connected an error message will flash on the LCD. After 20 seconds the selection is memorized.

12. **⊞ DEGAUSS (4)**

This is the degaussing button. It is used in case distortions or colour impurity caused by magnetic fields are present on the screen.

Remarks:

1. If the monitor remains inactive for more than 3 seconds the original video mode will appear on the LCD display.

2. **LANGUAGE SELECTION**

YOU MAY SELECT THE LANGUAGE ON THE LCD DISPLAY BY FOLLOWING THIS PROCEDURE:

(available languages: English, French, Italian, German, Spanish)

- Turn on your monitor.
- When the message "test in progress" appears on the LCD display, press any key on the front control panel.
- The LCD will display the selected language: ENGLISH.
- Press "Adjust +" to select your language.
- Press MEM. STORE to confirm your selection.
- Press the FUNCT. KEY to continue.

From now on when you switch on your monitor it will automatically display the chosen language.

3. **KEYBOARD LOCK FEATURE:**

Your monitor is equipped with a "keyboard lock" feature which allows the user to temporarily disable the front control panel.

TO "LOCK" THE FRONT CONTROL PANEL YOU MUST PRESS THE FOLLOWING KEY SEQUENCE:

+ (ADJUST), ↗ (MEMORY SELECT), ⊞ (DEGAUSS),
⊖ (INPUT SELECT)

Please note that you must press each key within 2 seconds for the keyboard lock to function. The message "keyboard locked" will appear on the LCD display if the sequence was successful. If no message is displayed on the LCD please repeat the operation.

TO "UNLOCK" THE FRONT CONTROL PANEL REPEAT THE SEQUENCE:

+ (ADJUST), ↗ (MEMORY SELECT), ⊞ (DEGAUSS),
⊖ (INPUT SELECT)

Please note that you must press each key within 2 seconds for the keyboard unlock this function. The message "unlocked" will appear on the LCD display if the sequence was successful. If no message is displayed on the LCD please repeat the operation.

10. Exploded view

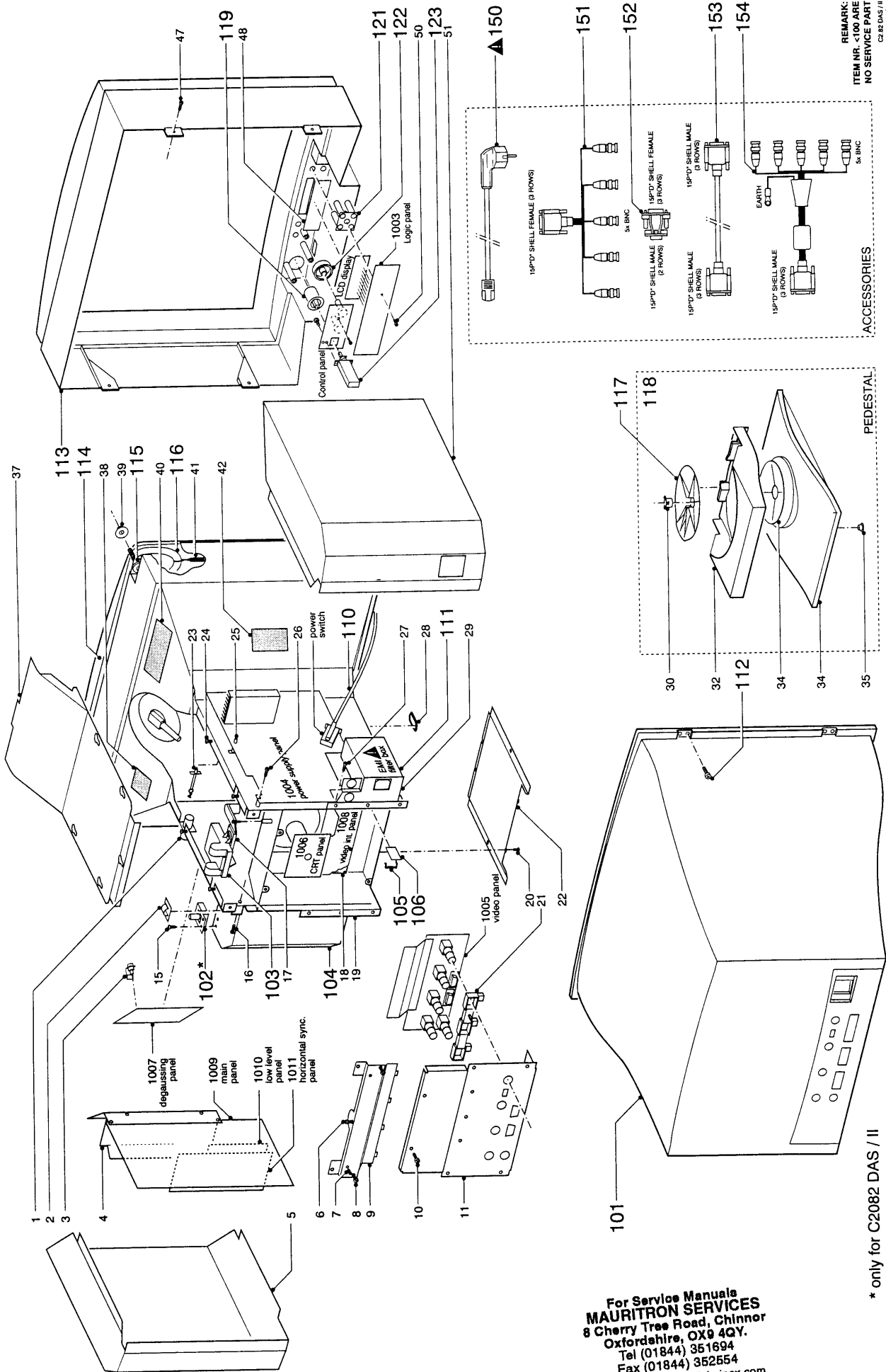

REMARK:
ITEM NR. <100 ARE
NO SERVICE PART
C2.82 DAS/II
CL 366301100011
02/94

ACCESSORIES

PEDESTAL

* only for C2082 DAS / II
and 2020DC

For Service Manuals
MAURITRON SERVICES
8 Cherry Tree Road, Chinnor
Oxfordshire, OX9 4QY.
Tel (01844) 351694
Fax (01844) 352654
email:- mauritron@dial.pipex.com

Spare parts lists

C2082DAS/II
2020DCREPAIRABLE PRINTED
WIRING BOARDS
(procedure via Philips Consumer Service)

1004	4822 212 30959	Power PWB
1005	4822 212 30932	Video PWB
1007	4822 212 30892	Degaussing PWB
1008	4822 212 30933	Video Int. PWB
1009	4822 212 30926	Main PWB
1010	4822 212 30927	Low Level PWB
1011	4822 212 30929	Hor.Sync. PWB

OTHER PRINTED WIRING
BOARDS

1003	4822 212 30931	Logic PWB (without EPROM ITEM 7704)
1006	4822 212 30173	CRT PWB
	4822 212 30961	Controls PWB

PARTS NOT ON PWB's
(See exploded view)

101	4822 438 10437	Rear cover with textplate
102	▲ 4822 101 11203	Static conv. potmeter
103	▲ 4822 212 30936	Focus unit
104	▲ 4822 212 30935	High tension box
105	4822 492 71122	Spring clip
106	4822 466 93141	Thermal insulator
110	4822 403 70975	ON/OFF extension
111	▲ 4822 265 31129	Mains socket assy
112	4822 502 21204	Screw M5X18
113	4822 451 70262	Mask + logo
114	▲ 4822 131 20479	Picture tube
115	4822 505 11137	Nut M6
116	▲ 4822 157 63964	Degaussing coil
117	4822 466 93301	Friction disc
118	4822 462 10562	Pedestal assy
119	4822 410 62817	ON/OFF Push button
121	4822 410 62816	Key
122	4822 410 62815	Knob
123	4822 272 20078	ON/OFF Switch (Mechanical)

KEY COMPONENTS ON
POWER PWB

F601	▲ 4822 253 30322	Fuse T0.2A 250V
F602	▲ 4822 070 34002	Fuse T4A 250V
S601	▲ 4822 272 20079	Mains switch
T601	▲ 4822 146 31278	Power tr. +200V
T602	▲ 4822 142 40335	Power tr. +5V

KEY COMPONENTS ON
MAIN PWB

F801	▲ 4822 071 51002	Fuse 1A 125V
------	------------------	--------------

KEY COMPONENTS ON
LOGIC PWB

7704	4822 900 10453	EPROM
	4822 130 91123	LCD Display

C2182DAS/II

REPAIRABLE PRINTED
WIRING BOARDS

(procedure via Philips Consumer Service)

1004	4822 212 30959	Power PWB
1005	4822 212 30932	Video PWB
1007	4822 212 30892	Degaussing PWB
1008	4822 212 30968	Video Int. PWB
1009	4822 212 30941	Main PWB
1010	4822 212 30927	Low Level PWB
1011	4822 212 30929	Hor.Sync. PWB

OTHER PRINTED WIRING BOARDS

1003	4822 212 30931	Logic PWB (without EPROM ITEM 7704)
1006	4822 212 30208	CRT PWB
	4822 212 30961	Controls PWB

PARTS NOT ON PWB's
(See exploded view)

101	4822 438 10437	Rear cover with textplate
103	▲ 4822 101 90246	Focus unit
104	▲ 4822 212 30935	High tension box
105	4822 492 71122	Spring clip
106	4822 466 93141	Thermal insulator
110	4822 403 70975	ON/OFF extension
111	▲ 4822 265 31129	Mains socket assy
112	4822 502 21204	Screw M5X18
113	4822 451 70263	Mask + logo
114	▲ 4822 131 20578	Picture tube
115	4822 505 11137	Nut M6
116	▲ 4822 157 70018	Degaussing coil
117	4822 466 93301	Friction disc
118	4822 462 10562	Pedestal assy
119	4822 410 62818	ON/OFF Push button
121	4822 410 62816	Key
122	4822 410 62815	Knob
123	4822 272 20078	ON/OFF Switch (Mechanical)

KEY COMPONENTS ON
POWER PWB

F601	▲ 4822 253 30322	Fuse T0.2A 250V
F602	▲ 4822 070 34002	Fuse T4A 250V
S601	▲ 4822 272 20079	Mains switch
T601	▲ 4822 146 31278	Power tr. +200V
T602	▲ 4822 142 40335	Power tr. +5V

KEY COMPONENTS ON MAIN
PWB

F801	▲ 4822 071 51002	Fuse 1A 125V
------	------------------	--------------

KEY COMPONENTS ON
LOGIC PWB

7704	4822 900 10454	EPROM
	4822 130 91123	LCD Display

ACCESSORIES

150	▲ 4822 321 10676	Power cord EUR
150	▲ 4822 321 10978	Power cord USA

151	4822 321 61241	I/F Cable (short) 5xBNC MALE-15P "D" Shell Female
-----	----------------	---

152	4822 263 50197	Adaptor 15p "D" Shell Female 3 Rows -15P "D" Shell Male 2 Rows
-----	----------------	--

153	4822 321 61529	I/F Cable 15p "D" Shell Male- 15P "D" Shell Male
-----	----------------	--

154	4822 321 61411	I/F Cable 5xBNC Male- 15P "D" Shell Male
-----	----------------	--

ACCESSORIES

150	▲ 4822 321 10676	Power cord EUR
150	▲ 4822 321 10978	Power cord USA

151	4822 321 61241	I/F Cable (short) 5xBNC MALE-15P "D" Shell Female
-----	----------------	---

152	4822 263 50197	Adaptor 15p "D" Shell Female 3 Rows -15P "D" Shell Male 2 Rows
-----	----------------	--

153	4822 321 61529	I/F Cable 15p "D" Shell Male- 15P "D" Shell Male
-----	----------------	--

154	4822 321 61411	I/F Cable 5xBNC Male- 15P "D" Shell Male
-----	----------------	--

Service
Service
Service

C2.82, 21A, 21B

94.01

Service Information

This service information covers all the following type numbers:

TYPE/CHASSIS	Survey:	
Old type number (until end Dec.'94)	New type number (as of Jan.'95)	Chassis
C2082DAS/..	No change	DAS
C2182DAS/..	No change	DAS
2082DC/..	No change	DAS
2182DC/..	No change	DAS
C2182DAS/HG	No change	PP (plus/plus)
C2190DAS/HG	21A11200/01S	21A90
C2190DAS/HS	21A11201/01S	21A90
C2190DAS/PC/HC	21B30300/01S	21B90
2190DC/PC/HC	21B30300/17S	21B90
2190DC/HG	21A11200/17S	21A90

1. LOGIC BOARD REPLACEMENT

If the logic board has to be replaced and it is not possible to place on the new panel the EEPROM (7703) original mounted on the defective panel, it is necessary to make a new monitor set up (including chromaticity and memory channels adjustments) by using the following procedures.

Equipment:- SOFTWARE PACKAGE RELEASE 2.1
(4822 727 20398)
- A WORKING MONITOR OF THE SAME TYPE
- RS232 CABLE (4822 321 21988)

INSTRUCTIONS

A Save the monitor set up from a working monitor

- 1a. Connect the monitor via the RS232 serial port to the computer and start the DATEST Release 2.1 software.
- 2a. Go to the utility menu EEPROM tools.
- 3a. Select "Save to disk", the program will ask you the name to save the file. If you are using a C2082DAS/II you can call the file with the same name of the monitor or other, as example C20DAS.
By pressing "+" you can see the names of the previous saved files.
At this moment you have saved the file on the same directory where you are running the DATEST program.
You can prepare a list of "master" files for the different monitor models. By doing so, this part of the instruction only has to be done once !

B Restore the set up into the repaired monitor

If during the repair you have to replaced the logic board, the new board has the EEPROM empty. If you connect the monitor to the computer, the DAS monitor does not recognise any type of factory timings.

- 1b. Connect the monitor via the RS232 serial port to the computer and start the DATEST Release 2.1 software.
- 2b. Go to the utility menu EEPROM tools.
- 3b. Select "Restore to DAS", the program will ask you the name of the file you want to restore. Following the above example you can restore C20DAS on the C2082DAS/II monitor.
By pressing "+" you can see the list of the saved files.
- 4b. At this moment you have restored all the parameters from the master monitor files. The factory preset timing has been restored, you have to readjust only the geometry and chromaticity parameters.

2. MAIN BOARD COMPATIBILITY

This information is valid only for the C2182DAS and 2182DC versions.

The main boards of above mentioned versions will be replaced by the main boards from the new 90 kHz sets.

The following table indicates the replacement reference:

VERSIONS	MAIN BOARD (OLD)	MAIN BOARD (NEW)
C2182DAS/HG 2182DC/HG	4822 212 31438	4822 212 31681 + change capacitor C806 from 270nF/630V to 330nF/630V (*)
C2182DAS/PC 2182DC/PC	4822 212 31515	4822 212 31682 + change capacitor C806 from 560nF/630V to 390nF/400V (*)

- THE POSITION OF THE NEW CAPACITOR C806 IS SHOWN IN FIGURE 1.

(*) This capacitor plus an instruction sheet will be packed into the FRU'S 4822 212 31681/31682

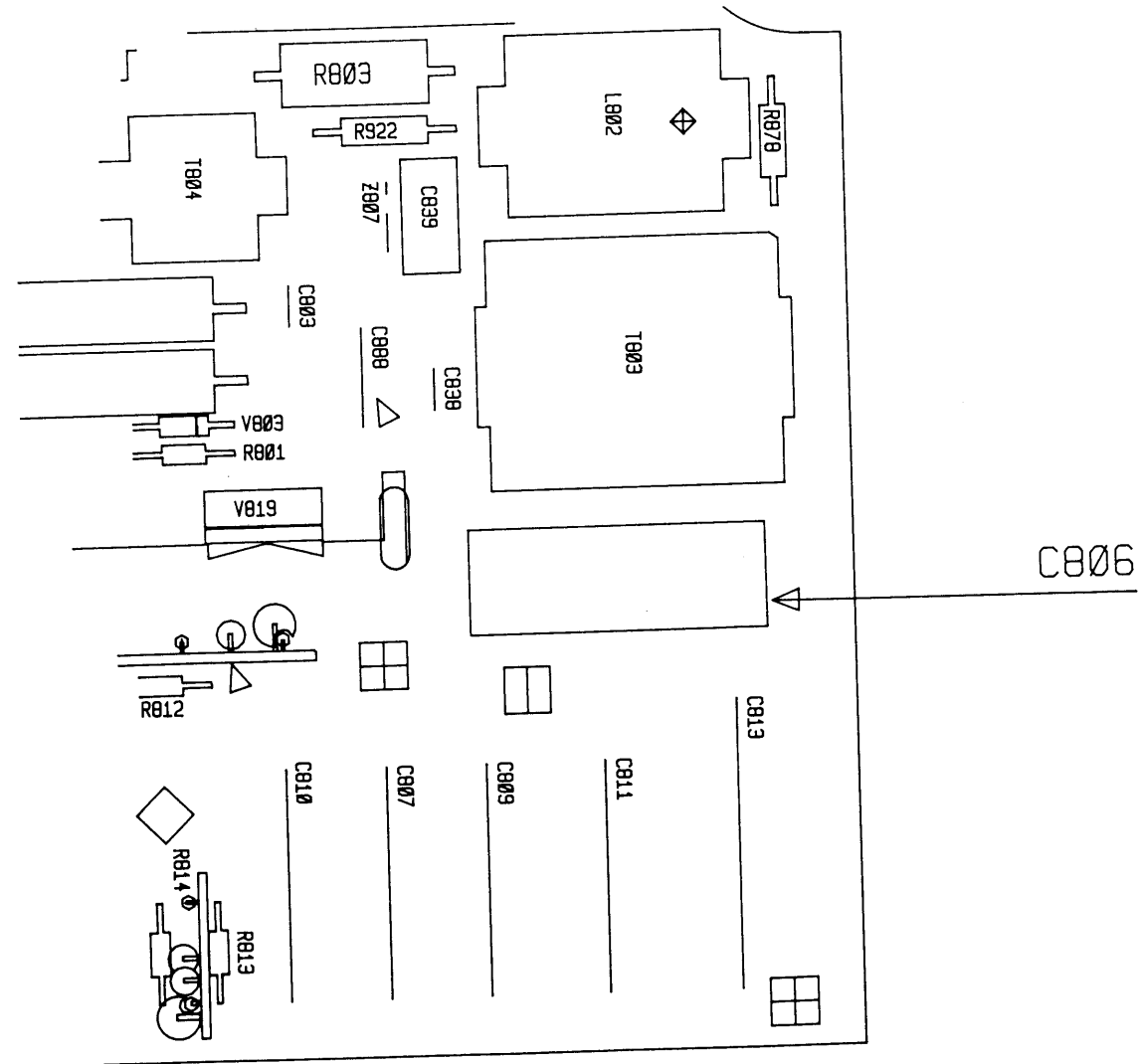

Fig. 1

Service
Service
Service

95.02

Service Information

Herewith publication 4822 727 20641 can be deleted.

This service information covers all the following type numbers:

- C2082DAS/..
- 2082DC/..
- C2182DAS/..
- 2182DC/..
- 21B30300/01S (C2190DAS/PC)
- 21B30300/17S (2190DC/PC)
- 21B30301/01S (C2190DAS/TT)
- 21BA9029/.. (CM0900PH /HI)
- C2082DAS/..
- 21A11200/01S (C2190DAS/HG)
- 21A11200/17S (2190DC/HG)
- 21A11201/01S (C2190DAS/HS)

Service Information

Herewith publication 4822 727 20654 can be deleted.

This service information covers all the following type numbers:

- C2082DAS/..
- 2082DC/..
- C2182DAS/..
- 2182DC/..
- 21B30300/01S (C2190DAS/PC)
- 21B30300/17S (2190DC/PC)
- 21B30301/01S (C2190DAS/TT)
- 21BA9029/.. (CM0900PH /HI)
- C2082DAS/..
- 21A11200/01S (C2190DAS/HG)
- 21A11200/17S (2190DC/HG)
- 21A11201/01S (C2190DAS/HS)

EPROM SURVEY				TYPE	C2082DAS/						C2182DAS/													
No.	SERVICE CODE	FACTORY CODE	VERSION OR RANGE	CHKS	A	2A	BA	II	IC	OI	A	2A	BA	II	III	PII	HA	III	HT	PA	IIIG			
					VER	CHKS																		
21	4822 900	3119 209	2.00A	63C0																				
			2.01A	DF38																				
			2.01B	F588																				
			2.01C	F64B																				
			2.01F	1FEA																				
			2.01G	246F																				
22	10672	13352	2.01H	3B0A																				
			3.10A	B318																				
			3.10B	B1DD																				
			1.00A	4A1D																				
			1.00B	0190																				
23	901 10005	13544	1.00C	B1DD																				

	AA 30 - 59	AA 60 - 79	01S - 17S	01S	01S-17S-75S	01S	00S

REASONS OF CHANGES / NOTES